



# UNITS & KITS

# Fast Finder

- AUXILIARY HEATERS ..... 519-526**
- BACKWALL MOUNT ..... 490-495**
- BUSES**
- School, Shuttle, and Transit ..... 528-530**
- CEILING MOUNT ..... 496-499**
- CONDENSERS & BRACKET KITS ..... 511**
- FACTORY TYPE - IN DASH**
- Drop-In Evaporator Kits ..... 504-508**
- FILTERS**
- Remote Mount Filters ..... 512**
- Air Filters - Evaporator ..... 326**
- FLOOR MOUNT (see Universal) ..... 509-510**
- HEATERS**
- Auxiliary ..... 519-526**
- Electric DC ..... 527**
- HOSE INSTALLATION KITS ..... 511**
- PRESSURIZERS / BOOSTER BLOWER ..... 512**
- REMOTE MOUNT**
- Condensers ..... 513-515**
- REMOTE MOUNT FILTERS ..... 512**
- ROOFTOP MOUNT**
- A/C Units ..... 501-503**
- Condensers ..... 516-518**
- UNIVERSAL MOUNT**
- Ceiling, Floor, or Under Dash ..... 509-510**

10-0026 ..... 512	10-9423 ..... 493	10-9803 ..... 519
10-0032 ..... 512	10-9440 ..... 504	10-9805 ..... 519
10-0033 ..... 512	10-9450 ..... 494	10-9806 ..... 519
10-0080 ..... 512	10-9451 ..... 494	10-9807 ..... 519
10-0081 ..... 512	10-9476 ..... 510	10-9808 ..... 519
10-0082 ..... 512	10-9477 ..... 510	10-9809 ..... 519
10-0085 ..... 512	10-9478 ..... 510	10-9815 ..... 525
10-0086 ..... 512	10-9610 ..... 503	10-9816 ..... 525
10-9275 ..... 505	10-9611 ..... 503	10-9817 ..... 525
10-9301 ..... 508	10-9710 ..... 490	10-9818 ..... 525
10-9302 ..... 508	10-9711 ..... 490	10-9819 ..... 525
10-9303 ..... 508	10-9712 ..... 491	10-9820 ..... 525
10-9320 ..... 508	10-9718 ..... 500	10-9821 ..... 525
10-9321 ..... 508	10-9719 ..... 500	10-9822 ..... 526
10-9335 ..... 528	10-9721 ..... 498	10-9823 ..... 526
10-9335F ..... 528	10-9722 ..... 498	10-9824 ..... 526
10-9335S ..... 528	10-9723 ..... 507	10-9825 ..... 526
10-9343 ..... 529	10-9724 ..... 491	10-9826 ..... 526
10-9343F ..... 529	10-9725 ..... 506	10-9827 ..... 526
10-9343S ..... 529	10-9726 ..... 506	10-9830 ..... 520
10-9350 ..... 513	10-9729 ..... 505	10-9831 ..... 520
10-9351 ..... 513	10-9730 ..... 505	10-9832 ..... 520
10-9355 ..... 529	10-9731 ..... 501	10-9833 ..... 520
10-9355F ..... 529	10-9732 ..... 501	10-9834 ..... 520
10-9355S ..... 529	10-9733 ..... 496	10-9840 ..... 520
10-9365 ..... 514	10-9734 ..... 496	10-9841 ..... 520
10-9366 ..... 514	10-9735 ..... 497	10-9842 ..... 520
10-9375 ..... 515	10-9736 ..... 497	10-9850 ..... 527
10-9376 ..... 515	10-9737 ..... 497	10-9851 ..... 527
10-9382 ..... 530	10-9738 ..... 497	10-9852 ..... 527
10-9383 ..... 530	10-9739 ..... 492	10-9853 ..... 527
10-9385 ..... 516	10-9740 ..... 492	10-9854 ..... 527
10-9386 ..... 516	10-9741 ..... 492	10-9855 ..... 527
10-9395 ..... 517	10-9742 ..... 492	10-9868 ..... 522
10-9396 ..... 517	10-9743 ..... 495	10-9870 ..... 523
10-9398 ..... 518	10-9744 ..... 495	10-9872 ..... 521
10-9399 ..... 518	10-9745 ..... 495	10-9880 ..... 524
10-9400 ..... 509	10-9746 ..... 495	10-9890 ..... 524
10-9401 ..... 509	10-9777 ..... 502	10-9891 ..... 524
10-9402 ..... 509	10-9778 ..... 502	10-9925 ..... 512
10-9403 ..... 509	10-9779 ..... 502	10-9928 ..... 512
10-9410 ..... 499	10-9780 ..... 502	10-9929 ..... 512
10-9420 ..... 493	10-9800 ..... 519	10-9936 ..... 512
10-9421 ..... 493	10-9801 ..... 519	
10-9422 ..... 493	10-9802 ..... 519	



# A/C & HEATER UNITS

## EVAPORATOR UNIT — BACKWALL MOUNT

FLEETS • HEAVY & MEDIUM DUTY TRUCKS • INDUSTRIAL • AGRICULTURE

The 10-9710 sets a new standard in air conditioning technology. It combines performance and styling in a package small enough to fit almost anywhere. In addition, it utilizes engineered resin technology to create a unit that is not only attractive but incredibly durable. The 10-9710 utilizes advanced coil and blower technology to create the highest capacity possible in a wall mounted unit that is no more than 11-1/4" wide.



### Not Sure What To Order? We Can Help . . .

See the **A/C System Configuration Worksheet** on the last page of this catalog.

#### A/C Unit Requires:

- A/C Compressor
- Hose Kit #9850
- Engine Compressor Bracket Kit
- Condenser
- Condenser Brackets

BACKWALL

#### PART NO.

**10-9710** ..... 12v  
**10-9711** ..... 24v

#### SHIPPING NOTICE

This unit can be shipped by UPS.

#### SPECIFICATIONS

Air Flow ..... 260 CFM  
Capacity ..... Cooling - 17,180 BTU/Hr with 36°F (4,329 kcal/h with 2.2°C) refrigerant temp. and 80°F (26.7°C) wet bulb entering air  
Current Draw ..... 18 amps @ 13.6 VDC (includes 4 amps for A/C clutch)  
9 amps @ 27.2 VDC (includes 2 amps for A/C clutch)  
Weight ..... 16 lbs. (11 kg)

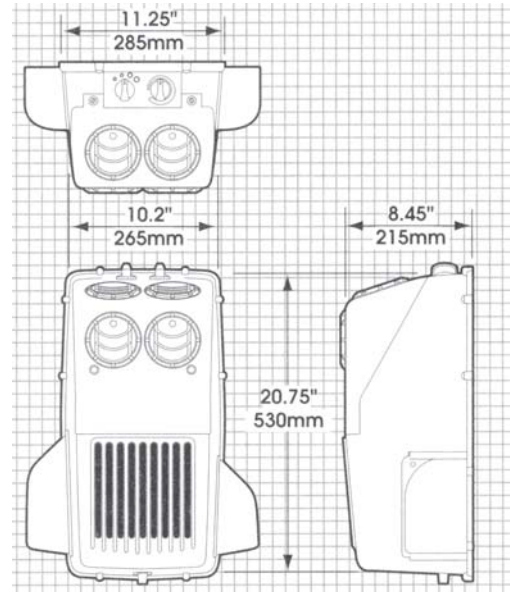

#### OPTIONS

**10-0090**  
Floor Support Kit



**10-0091**  
Plumbing Covers



**10-0092**  
Recirculation Filter

Remote Control Panel  
RD-2-3674-0

#### SERVICE PARTS

	<b>Part No.</b>
Blower Motor Assembly - 12v .....	73R 5572
Blower Motor Assembly - 24v .....	73R 5574
Evaporator .....	RD-2-5125-0
Expansion Valve .....	<b>1600</b>
Knob, Rotary Control .....	71R-4025

	<b>Part No.</b>
Louver .....	<b>1734</b>
Resistor, Speed Control .....	<b>1220</b>
Switch, 3 Speed, Rotary (25 amp) .....	71R-1170
Thermostatic Switch .....	<b>1336</b>

## EVAPORATOR UNIT — BACKWALL MOUNT

FLEETS • HEAVY & MEDIUM DUTY TRUCKS • INDUSTRIAL • AGRICULTURE

The 10-9712 blasts ice cold high velocity air where you want it. Multi-directional diffusers are positioned directly over the blower so you get cool air right off the coil in any direction. This compact high-capacity unit easily mounts between the seats to back walls in most class 6-8 conventional cabs. It can also be front dash mounted in some class 6 and 7 vehicles where a flat space permits. The 10-9712 is designed to provide maximum cooling with a minimum of maintenance. The welded steel construction uses only nut plates and is void of troublesome sheetmetal screws. It's unique design which provides access to any components in minutes is a fleet dream and a breath of fresh air to owner operators tired of bruised knuckles under the dash. A backwall/floor support kit option is available for added reinforcement.



### Not Sure What To Order? We Can Help . . .

See the A/C System  
Configuration Worksheet  
on the last page of this catalog.

**A/C Unit Requires:**

- A/C Compressor
- Hose Kit #9850
- Engine Compressor Bracket Kit
- Condenser
- Condenser Brackets

**PART NO.**

**10-9712** ..... 12v  
**10-9724** ..... 24v

**SHIPPING NOTICE**

This unit can be shipped by UPS.

**SPECIFICATIONS**

Air Flow ..... 260 CFM  
Capacity ..... Cooling - 17,180 BTU/Hr with 36°F (4,329 kcal/h with 2.2°C) refrigerant temp. and 80°F (26.7°C) wet bulb entering air  
Current Draw ..... 18 amps @ 13.6 VDC (includes 4 amps for A/C clutch) 9 amps @ 27.2 VDC (includes 2 amps for A/C clutch)  
Weight ..... 25 lbs. (11 kg)

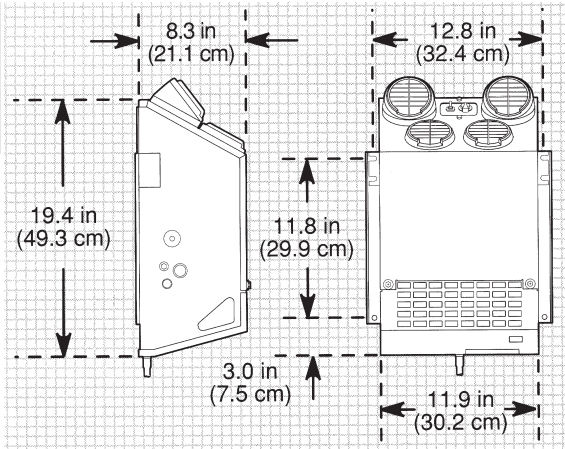

BACKWALL

**OPTIONS**

<b>10-0001</b> Floor Support Kit	<b>10-0002</b> Recirculation Filter
-------------------------------------	--

**SERVICE PARTS**

<u>Part No.</u>	<u>Part No.</u>
Blower Motor - 12v ..... <b>3402</b>	Knob ..... <b>1271</b>
Blower Motor - 24v ..... <b>3373</b>	Louver (top) (2) ..... <b>1720</b>
Blower Wheel ..... <b>3750</b>	Louver (bottom) (2) ..... <b>RD-5-5222-0</b>
Control Panel Assm. (fixed) ..... <b>RD-2-1487-1</b>	Resistor ..... <b>1220</b>
Control Panel Assm. (variable) ..... <b>RD-2-1487-0</b>	Switch, ON-OFF-ON ..... <b>1060</b>
Drain Hose ..... <b>8528</b>	Thermostatic Sw. (preset 24" cap.) ..... <b>1332</b>
Evaporator ..... <b>6507</b>	Thermostatic Sw. (rotary 36" cap.) ..... <b>1336</b>
Expansion Valve (R134a) ..... <b>1600</b>	

# A/C & HEATER UNITS

## EVAPORATOR UNIT — BACKWALL MOUNT (WITH HEAT OPTION)

CONSTRUCTION • MINING • AGRICULTURAL

With the emergence of smaller cabs comes the demand for systems that deliver paramount performance while requiring minimum space. The versatility of the 10-9739 allows the air plenum to be changed to divert the air out the top or the front of the unit depending on the application. In addition, the controls can be remote mounted. Utilizing quality components throughout, this unit promises to provide hassle free maintenance and exemplary performance.

**Not Sure What To Order?  
We Can Help . . .**

See the A/C System  
Configuration Worksheet  
on the last page of this catalog.



**A/C Unit Requires:**

- A/C Compressor
- Hose Kit #9850
- Engine Compressor Bracket Kit
- Condenser
- Condenser Brackets

BACKWALL

**PART NO.**

- 10-9739** ..... Heater/Air Conditioner - 12v
- 10-9740** ..... Heater/Air Conditioner - 24v
- 10-9741** ..... Air Conditioner Only - 12v
- 10-9742** ..... Air Conditioner Only - 24v

**SHIPPING NOTICE**

This unit can be shipped by UPS.

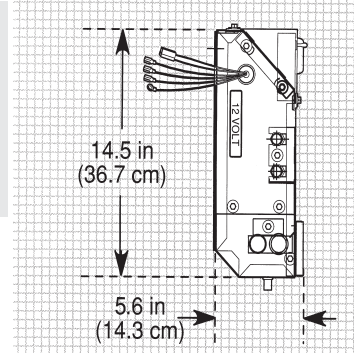

**SPECIFICATIONS**

- Air Flow ..... 205 CFM (348 m<sup>3</sup>/h)
- Capacity ..... Heating - 22,000 BTU/Hr @ 100°F (5,544 kcal/h @ 37.8°C)  
Cooling - 15,200 BTU/Hr @ 36°F (3,840 kcal/h @ 2.2°C)
- Current Draw ..... 13.5 amps @ 13.6 VDC (includes 4 amps for A/C clutch)  
6.75 amps @ 27.2 VDC (includes 2 amps for A/C clutch)
- Weight ..... 24 lbs. (11 kg)

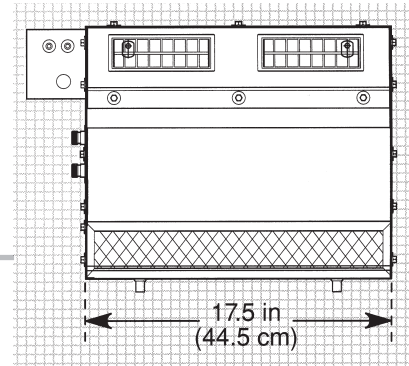

**OPTIONS**

**10-0017**  
Plenum Assembly

**10-0023**  
Duct Kit

Control Panel  
A/C only ..... RD3-6100-0  
A/C - Heat ... RD3-6082-0

**SERVICE PARTS**

<b>Part No.</b>	<b>Part No.</b>
Blower Motor Assembly - 12v ..... <b>3982</b>	Louver (rectangle) (2) ..... RD-5-6987-0
Blower Motor Assembly - 24v ..... RD-3-6062-1	Louver (round) (3) ..... RD-5-5222-0
Blower Wheel (2) ..... <b>3715</b>	Relay - 12v ..... <b>1263</b>
Circuit Breaker, 15 amp - 24v ..... <b>1211</b>	Relay - 24v ..... <b>1264</b>
Circuit Breaker, 30 amp - 12v ..... <b>1210</b>	Switch (Heat-A/C) ..... <b>1060</b>
Evaporator ..... 76R-5030	Switch, (A/C Only) ..... <b>1020</b>
Expansion Valve ..... <b>1600</b>	Switch, Fan ..... <b>1028</b>
Filter (Recirculation) ..... <b>10-9914</b>	Thermostatic Switch ..... <b>1332</b>
Heater Core ..... 76R-1030	



## EVAPORATOR UNIT — BACKWALL MOUNT

ARMORED CARS • AID CARS • PERSONNEL CARRIERS • OFF ROAD CABS

The 10-9420 is an ideal unit for armored car applications because the system can direct heated or cooled air to both front and rear compartments through multi-directional louvers. The tremendous capacity of this unit also makes it ideal for aid car, delivery truck or large box applications. The 10-9420 also offers simple service and an evaporator filter.



### Not Sure What To Order? We Can Help . . .

See the A/C System  
Configuration Worksheet  
on the last page of this catalog.

#### A/C Unit Requires:

- A/C Compressor
- Hose Kit #9850
- Engine Compressor Bracket Kit
- Condenser
- Condenser Brackets

#### PART NO.

- 10-9420** ..... Rear Exhaust - 12v
- 10-9421** ..... Rear Exhaust - 24v
- 10-9422** ..... Fresh Air Intake - 12v
- 10-9423** ..... Fresh Air Intake - 24v

#### SHIPPING NOTICE

This unit can be shipped by UPS.

#### SPECIFICATIONS

- Air Flow ..... 430 CFM (348 m<sup>3</sup>/h)
- Capacity ..... Heating - 46,000 BTU/Hr @ 150°F (11,592 kcal/h @ 66°C)  
Cooling - 33,000 BTU/Hr @ 36°F (8,316 kcal/h @ 2.2°C)
- Current Draw ..... 22 amps @ 13.6 VDC (includes 4 amps for A/C clutch) 11.2  
amps @ 27.2 VDC (Includes 2 amps for A/C clutch)
- Weight ..... 47 lbs. (11 kg)

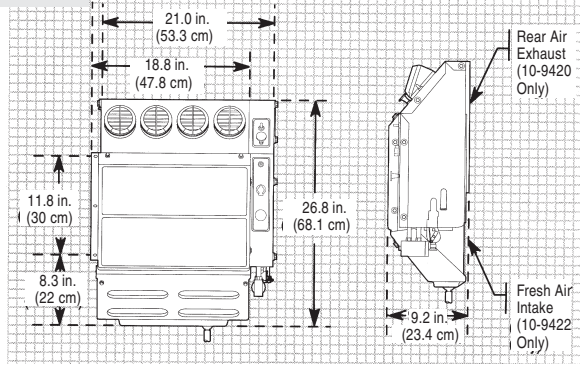

#### OPTIONS

- 10-0019** Bulkhead Louver Kit For Rear Exhaust Unit
- 10-0032** ..... 12 volt
- 10-0033** ..... 24 volt



**Louver Assembly (rear)**  
RD3-3133-0

#### SERVICE PARTS

	<u>Part No.</u>		<u>Part No.</u>
Blower Assembly - 12v .....	RD-3-2547-0	Knob (cable) (2) .....	<b>1272</b>
Blower Assembly - 24v .....	RD-3-2547-1	Knob (control) (1) .....	<b>1271</b>
Blower Wheel (2) .....	<b>3750</b>	Louver, round (4) .....	RD5-5223-2
Control Cable (2) .....	72R-7290	Motor 12v .....	<b>3322</b>
Control Panel Assembly .....	<b>1719</b>	Motor 24v .....	<b>3472</b>
Evaporator .....	76R-7070	Reisistor .....	<b>1220</b>
Expansion Valve .....	<b>1600</b>	Switch 3 speed (a/c only) .....	<b>1150</b>
Filter (air) .....	<b>9940</b>	Switch, Toggle (4 terminal) .....	<b>1028</b>
Heater Core .....	76R-3500	Switch, Toggle (6 terminal) .....	<b>1060</b>
Heater Valve .....	<b>2210</b>	Thermostatic Switch (2) .....	<b>1336</b>

# A/C & HEATER UNITS

## EVAPORATOR UNIT — BACKWALL MOUNT

CONSTRUCTION • MINING • AGRICULTURAL

The 10-9450 is a beefed up unit with a heavy duty all metal housing designed for off road applications. Designed specifically for high capacity applications, this unit also offers fresh air intake and can be pressurized.



**Not Sure What To Order?  
We Can Help . . .**

**See the A/C System  
Configuration Worksheet  
on the last page of this catalog.**

**A/C Unit Requires:**

- A/C Compressor
- Hose Kit #9850
- Engine Compressor Bracket Kit
- Condenser
- Condenser Brackets

BACKWALL

**PART NO.**

- 10-9450** ..... 12v
- 10-9451** ..... 24v

**SHIPPING NOTICE**

This unit can be shipped by UPS.

**SPECIFICATIONS**

- Air Flow ..... 430 CFM (348 m<sup>3</sup>/h)
- Capacity ..... Heating - 46,000 BTU/Hr @ 150°F (11,592 kcal/h @ 66°C)  
Cooling - 33,000 BTU/Hr @ 36°F (8,316 kcal/h @ 2.2°C)
- Current Draw ..... 21.8 amps @ 13.6 VDC (includes 4 amps for A/C clutch)  
10.9 amps @ 27.2 VDC (Includes 2 amps for A/C clutch)
- Weight ..... 47 lbs. (11 kg)

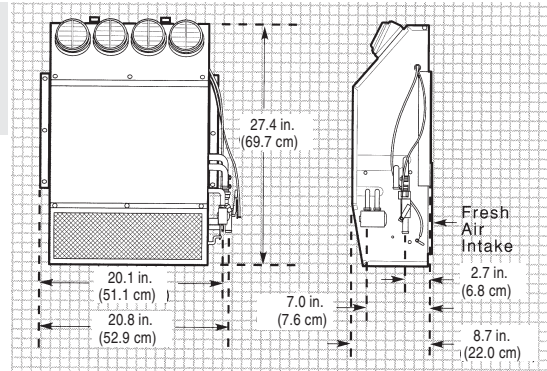

**OPTIONS**

- 10-0032** ..... 12 volt
  - 10-0033** ..... 24 volt
- Inline Booster Pressurizer



- 9916**
- Fresh Air Intake  
(replacement filter)

- 10-9918**
- Fresh Air Intake Filter

**SERVICE PARTS**

	<u>Part No.</u>	<u>Part No.</u>
Blower Assembly - 12v .....	RD-3-2547-0	Louver (4) .....
Blower Assembly - 24v .....	RD-3-2547-1	Motor - 12v .....
Blower Wheel .....	<b>3750</b>	Motor - 24v .....
Evaporator .....	76R-7070	Resistor Speed Control .....
Expansion Valve .....	<b>1600</b>	Rotary Actuator Assembly .....
Filter (recirculation) .....	<b>10-9912</b>	Switch, OFF-ON-ON 12v .....
Heater Core .....	76R-3500	Switch, OFF-ON-ON 24v .....
Heater Valve, cable operated .....	<b>2283</b>	Switch, Rocker, Fan ON-ON-ON .....
Knob (control) .....	<b>1289</b>	Thermostatic Switch .....
		<b>1719</b>
		<b>3322</b>
		<b>3472</b>
		<b>1220</b>
		RD5-8152-27.8
		<b>1109</b>
		<b>1110</b>
		<b>1111</b>
		<b>1331</b>

## EVAPORATOR UNIT — BACKWALL MOUNT (WITH HEAT OPTION)

CONSTRUCTION • MINING • AGRICULTURAL

Compact and powerful are the best words to describe the 10-9743. Inch for inch it has the highest output of any unit its size in the off road. It is constructed of heavy guage coated steel and engineered to filter in-cab air as well as incoming outside air when pressurization is required. The 10-9743's high-performance, rugged construction and serviceability make it ideal for all off road applications where space is a minimum and dependability essential.



**Not Sure What To Order?  
We Can Help . . .**

See the A/C System  
Configuration Worksheet  
on the last page of this catalog.

**A/C Unit Requires:**

- A/C Compressor
- Hose Kit #9850
- Engine Compressor Bracket Kit
- Condenser
- Condenser Brackets

**PART NO.**

- 10-9743** ..... Heater/Air Conditioner - 12v
- 10-9744** ..... Heater/Air Conditioner - 24v
- 10-9745** ..... Air Conditioner Only - 12v
- 10-9746** ..... Air Conditioner Only - 24v

**SHIPPING NOTICE**

This unit can be shipped by UPS.

**SPECIFICATIONS**

- Air Flow** ..... 265 CFM (450 m<sup>3</sup>/h)
- Capacity** ..... Heating - 28,600 BTU/Hr @ 100°F (7,207 kcal/h @ 37.8°C)  
Cooling - 18,000 BTU/Hr @ 36°F (4,536 kcal/h @ 2.2°C)
- Controls** ..... Mode selector switch (heat or A/C), three speed fan switch, fixed setting thermostat, cable controlled water valve.
- Current Draw** ..... 16.1 amps @ 13.6 VDC (includes 4 amps for A/C clutch) 8 amps @ 27.2 VDC (Includes 2 amps for A/C clutch).
- Motor** ..... Totally sealed 12 or 24 volt permanent magnet type with long life brushes and heavy duty pre-lubricated sealed ball bearings.
- Weight** ..... 39 lbs. (18 kg)

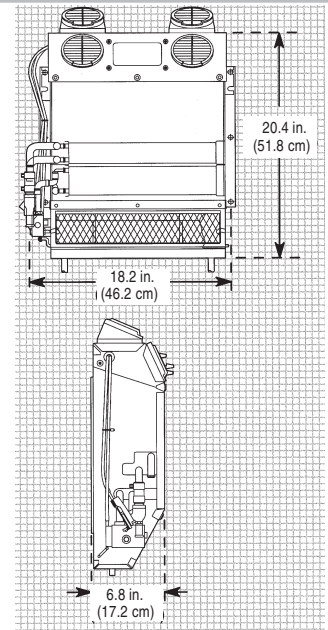

BACKWALL

**OPTIONS**

**10-0020**  
3" Outside Air Adapter

**10-0022**  
Heater Conversion Kit - to convert  
previously installed 10-9745/10-9746 units

**10-0023**  
Universal Duct Kit

**10-0026**  
Remote Mount Filter  
Horizontal

**10-0032** ..... 12 volt  
**10-0033** ..... 24 volt  
Inline Booster Pressurizer

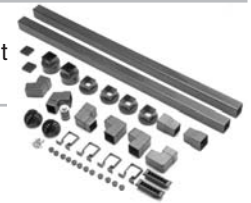

**SERVICE PARTS**

	<b>Part No.</b>
Blower Motor - 12v .....	<b>3949</b>
Blower Motor - 24v .....	73R-4264
Blower Motor Assembly - 12v .....	RD-2-1206-2
Blower Motor Assembly - 24v .....	<b>3911</b>
Blower Wheel (CW) .....	<b>3610</b>
Blower Wheel (CCW) .....	<b>3611</b>
Control Cable .....	72R-8190
Evaporator .....	<b>6677</b>
Expansion Valve .....	<b>1600</b>
Filter (recirculation) .....	<b>10-9935</b>

	<b>Part No.</b>
Heater Core .....	<b>6955</b>
Heater Valve .....	<b>2280</b>
Knob .....	71R-4035
Lever Control .....	RD-3-4096-0
Louver (top-swivel) (2) .....	<b>1719</b>
Louver (front) (2) .....	<b>1720</b>
Resistor .....	<b>1220</b>
Switch - Fan, SPST .....	<b>1050</b>
Switch - Toggle, SPST .....	<b>1020</b>
Thermostatic Switch .....	<b>1331</b>





## EVAPORATOR UNIT — CEILING MOUNT

CONSTRUCTION • MINING • INDUSTRIAL

The 10-9735 is the ultimate choice in off road air conditioning comfort. It is capable of producing a quick 240 CFM and filters recirculating cab air. Cab pressurization can be added using an outside air adapter and particulate filter. A HEATER OPTION rounds out the 10-9735 into a perfect package for equipment manufacturers looking for a powerful product in a minimum of space.

**Not Sure What To Order?  
We Can Help . . .**

See the A/C System Configuration Worksheet on the last page of this catalog.

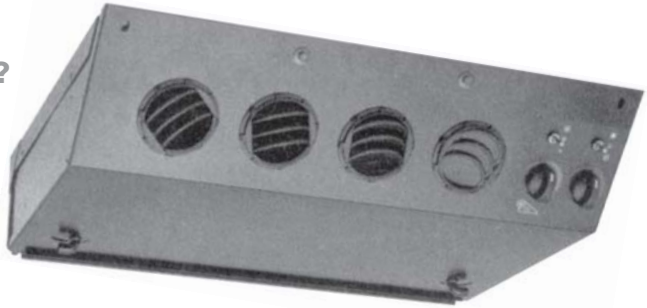

**A/C Unit Requires:**

- A/C Compressor
- Hose Kit #9850
- Engine Compressor Bracket Kit
- Condenser
- Condenser Brackets

<u>PART NO.</u>	<u>SHIPPING NOTICE</u>
<b>10-9735</b> ..... Heater/Air Conditioner - 12v	This unit can be shipped by UPS.
<b>10-9736</b> ..... Heater/Air Conditioner - 24v	
<b>10-9737</b> ..... Air Conditioner Only - 12v	
<b>10-9738</b> ..... Air Conditioner Only - 24v	

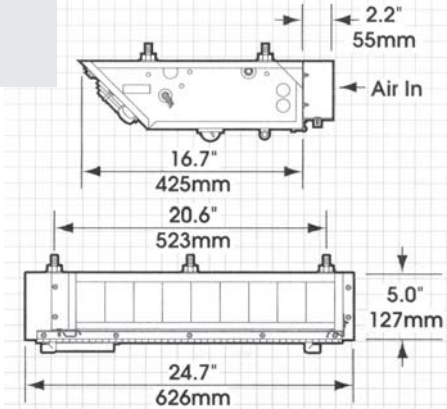

**SPECIFICATIONS**

Air Flow ..... 240 CFM  
 Capacity ..... Cooling - 17,000 BTU/Hr with 36°F (4.272 kcal/h with 2.2°C) refrigerant temp. and 80°F (26.7°C) wet bulb entering air  
 Heating - 25,600 BTU/Hr @ 100°F (6,451 kcal/h @ 37.8°C) air temp. rise  
 Current Draw ..... 13 amps @ 13.6 VDC (includes 4 amps for A/C clutch) 6.5 amps @ 27.2 VDC (includes 2 amps for A/C clutch)  
 Weight ..... 39 lbs. (18 kg)



CEILING

**OPTIONS**

<b>10-0010</b> Fresh Air Box Assembly	<b>10-0026</b> ..... Horizontal <b>10-9936</b> ..... Vertical Remote Mount Filter		<b>10-0032</b> ..... 12 volt <b>10-0033</b> ..... 24 volt Inline Booster Pressurizer	
<b>10-9911</b> Fresh Air Replacement Filter			<b>10-0036</b> Heater Conversion Kit - to convert previously installed 10-9737/10-9738 units	

**SERVICE PARTS**

<u>Part No.</u>	<u>Part No.</u>
Blower Motor Assembly - 12v ..... <b>3996</b>	Heater Valve ..... <b>2284</b>
Blower Motor Assembly - 24v ..... <b>3997</b>	Knob, Control, Rotary ..... <b>RD-5-8812-0</b>
Control Cable 34" ..... <b>2534</b>	Louvers (4) ..... <b>1734</b>
Evaporator ..... <b>6676</b>	Switch, A/C only Toggle SPST ..... <b>1020</b>
Expansion Valve ..... <b>1600</b>	Switch, Toggle DPDT ..... <b>1060</b>
Fresh Air Box Assembly ..... <b>10-0010</b>	Switch, Toggle SPDT ..... <b>1028</b>
Heater Conversion Kit ..... <b>10-0036</b>	Thermostatic Sw. (rotary 36" cap.) ..... <b>1336</b>
Heater Core ..... <b>6953</b>	



## EVAPORATOR UNIT — CEILING MOUNT

BUSES • VANS • FIRE TRUCKS

Offering a big airflow of 577 CFM, the 10-9410 is one of the highest capacity and best quality headliner air conditioners on the market. It can be used in a variety of larger cab applications such as: shuttle buses/vans, fire trucks, and smaller school buses. The electric water pump can be used in tilt cab situations or in extremely humid applications.



**A/C Unit Requires:**

- A/C Compressor
- Hose Kit #9850
- Engine Compressor Bracket Kit
- Condenser
- Condenser Brackets



**PART NO.**

**10-9410** ..... 12v

**SHIPPING NOTICE**

This unit can be shipped by UPS.

**SPECIFICATIONS**

- Air Flow ..... 577 CFM
- Capacity ..... Cooling - 39,500 BTU/Hr with 36°F (9,954 kcal/h with 2.2°C)
- Current Draw ..... 26.3 amps @ 13.6 VDC (includes 4 amps for A/C clutch)  
13.2 amps @ 27.2 VDC (includes 2 amps for A/C clutch)
- Weight ..... 33 lbs. (11 kg)

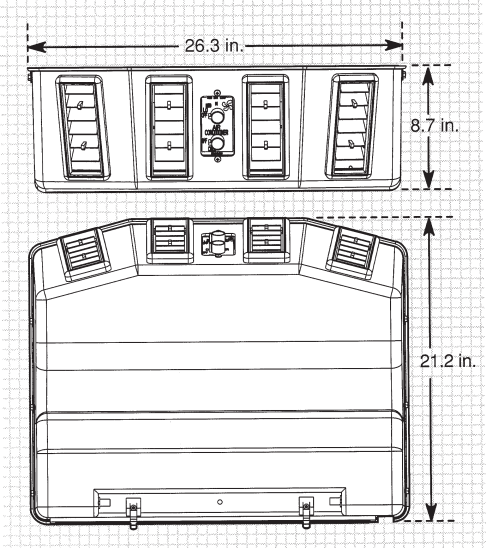

CEILING

**OPTIONS**

**2844**  
Electric Water Pump  
Moisture Sensor Kit



**Not Sure What To Order?  
We Can Help . . .**

See the A/C System  
Configuration Worksheet  
on the last page of this catalog.

**SERVICE PARTS**

	<u>Part No.</u>
Blower Motor Assembly - 12v .....	73R5502
Blower Motor Assembly - 24v .....	73R5504
Evaporator .....	76R6040
Expansion Valve .....	<b>1602</b>
Filter .....	<b>9939</b>
Knob .....	<b>1271</b>
Louver (4) .....	<b>1714</b>
Pump (condensate) .....	RD-5-8424-0

	<u>Part No.</u>
Relay - 12v .....	<b>1250</b>
Relay - 24v .....	<b>1251</b>
Resistor .....	<b>1220</b>
Switch, Fan 3 Speed .....	<b>1150</b>
Switch Assembly - 12v .....	RD-5-8425-1
Switch Assembly - 24v .....	RD-5-8425-3
Thermostatic Switch .....	<b>1336</b>





## A/C UNIT — ROOFTOP MOUNT

CONSTRUCTION • MINING • AGRICULTURAL

The 10-9731 has set the standard in the off highway market for rooftop air conditioning. Years of development have made this unit the most rugged, dependable and serviceable unit in the industry. It's heavy guage steel construction and heavy duty components assure trouble free operation in the most extreme environments. Should service be necessary, rubber hood tie-downs unlatch and expose easily removable components to minimize expensive down time.

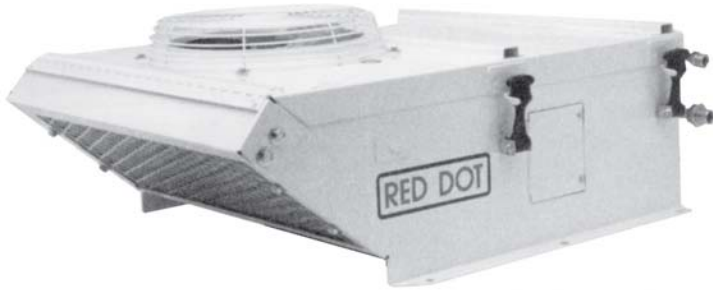

**A/C Unit Requires:**

- A/C Compressor
- Hose Kit #9855
- Engine Compressor Bracket Kit

**PART NO.**

- 10-9731** ..... 12v
- 10-9732** ..... 24v

**SHIPPING NOTICE**

Due to size and weight, this unit must be shipped by LTL Carrier.

**SPECIFICATIONS**

- Air Flow ..... Evaporator - 320 CFM (544 m<sup>3</sup>/h)  
Condenser - 850 CFM (1444 m<sup>3</sup>/h)
- Capacity ..... 22,000 BTU/Hr (5,544 kcal/h)
- Current Draw ..... 29 amps @ 13.6 VDC (includes 4 amps for A/C clutch) 15 amps @ 27.2 VDC (includes 2 amps for A/C clutch)
- Weight ..... 104 lbs. (47 kg)

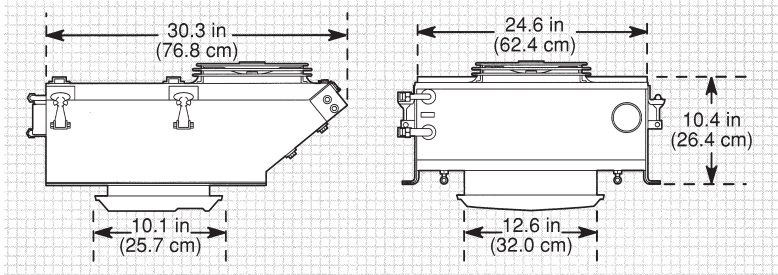

ROOFTOP

**OPTIONS**

- 10-0026** ..... Horizontal
- 10-9936** ..... Vertical
- Remote Mount Filter
- 10-9929** ..... Repl. Filter



- 10-0032** ..... 12 volt
- 10-0033** ..... 24 volt
- Inline Booster Pressurizer
- 9931** ..... Pressurizer Inlet Cap



- 10-0045**
- Fresh Air Filter Box

- 10-9925** ..... Backpack Filter
- 9928** ..... Repl. Filter



- 10-0050**
- Stiffener Brackets



- 10-0055**
- Winter Cover

**SERVICE PARTS**

	<u>Part No.</u>	<u>Part No.</u>	
Blower Motor Assembly - 12v	<b>3909</b>	Louver Assembly 4-1/2" (2)	<b>1730</b>
Blower Motor Assembly - 24v	<b>RD-5-3860-5</b>	Motor, Blower (Evaporator) - 12v	<b>3232</b>
Blower Wheel	<b>3625</b>	Motor, Blower (Evaporator) - 24v	<b>3224</b>
Blower Wheel	<b>3626</b>	Motor, Condenser - 12v	<b>3512</b>
Condenser	<b>6050</b>	Motor, Condenser - 24v	<b>3514</b>
Drain Hose	<b>8528</b>	Plenum Assembly	<b>RD-2-1290-0</b>
Evaporator	<b>6592</b>	Receiver Drier	<b>7126</b>
Expansion Valve	<b>1600</b>	Resistor	<b>1220</b>
Fan Blade, 10"	<b>3810</b>	Switch, 3 speed	<b>1150</b>
Filter, Recirculation	<b>9930</b>	Switch, Pressure, Binary	<b>1510</b>
Gasket (Plenum)	<b>RD-2-1297-0</b>	Thermostatic Switch	<b>1336</b>
Knob (2)	<b>1271</b>		

# A/C & HEATER UNITS

## A/C Unit — ROOFTOP MOUNT (WITH HEAT OPTION)

CONSTRUCTION • MINING • AGRICULTURAL

The 10-9777 rooftop unit uses the latest design techniques to produce a rugged unit, which combines Euro styling with heavy duty components that will withstand the roughest applications. The 10-9777 Heater/Air Conditioner is the first in the industry to employ engineered resin technology. This Euro styling and design sets this unit far beyond the competition in appearance, durability and performance.



### A/C Unit Requires:

- A/C Compressor
- Hose Kit #9855
- Engine Compressor Bracket Kit

ROOFTOP

### PART NO.

- 10-9777** ..... Heater A/C - 12v  
**10-9778** ..... Heater A/C - 24v  
**10-9779** ..... A/C Only - 12v  
**10-9780** ..... A/C Only - 24v

### SHIPPING NOTICE



Due to size and weight, this unit must be shipped by LTL Carrier.

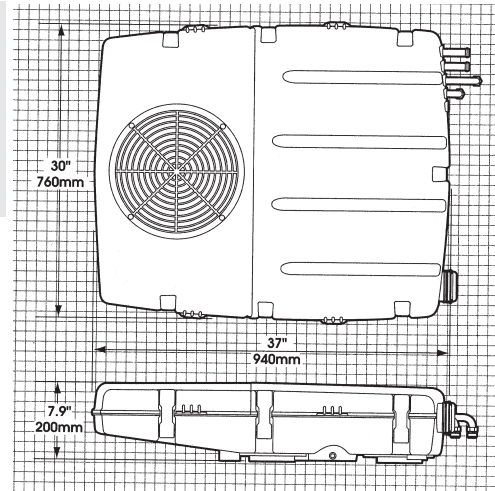

### SPECIFICATIONS

- Air Flow ..... 400 CFM  
 Capacity ..... Cooling - 25,000 BTU/Hr with 36°F (7.3kW with 2.2°C) refrigerant temp. and 80°F (26.7°C) wet bulb entering air  
 Heating - 45,000 BTU/Hr @ 100°F (13.2kW @ 37.8°C) air temp. rise  
 Current Draw ..... 38.2 amps @ 13.6 VDC (includes 4 amps for A/C clutch)  
 19.1 amps @ 27.2 VDC (includes 2 amps for A/C clutch)  
 Weight ..... 65 lbs.

### OPTIONS

- 10-0026** ..... Horizontal  
**10-9936** ..... Vertical  
 Remote Mount Filter



- 10-0032** ..... 12 volt  
**10-0033** ..... 24 volt  
 Inline Booster Pressurizer



### SERVICE PARTS

	<u>Part No.</u>		<u>Part No.</u>
Binary Switch .....	<b>1511</b>	Louver .....	72R-3140
Blower Assembly - 12v .....	<b>3998</b>	Receiver Drier .....	<b>7555</b>
Blower Assembly - 24v .....	<b>3999</b>	Relay - 12v .....	<b>1261</b>
Condenser .....	<b>6308</b>	Relay - 24v .....	<b>1262</b>
Condenser Fan - 12v .....	<b>06-2612</b>	Resistor - 12v .....	71R-1402
Condenser Fan - 24v .....	<b>06-2613</b>	Resistor - 24v .....	<b>1364</b>
Evaporator .....	76R-5820	Rocker Switch .....	71R-0840
Expansion Valve .....	<b>1602</b>	Rotary Switch .....	71R-1160
Heater Core .....	76R-1650	Thermostatic Switch .....	<b>1332</b>
Knob .....	RD5-8812-0		

## A/C UNIT — ROOFTOP MOUNT (WITH HEATER)

CONSTRUCTION • MINING • AGRICULTURAL

The 10-9610 rooftop heater/air conditioner is designed with versatility and dependability in mind. In addition, this unit comes with **HEAT**. It is a solid, dependable unit utilizing the most rugged and highest quality components available.



**A/C Unit Requires:**

- A/C Compressor
- Hose Kit #9855
- Engine Compressor Bracket Kit

**PART NO.**

**10-9610** ..... 12v  
**10-9611** ..... 24v

**SHIPPING NOTICE**



Due to size and weight, this unit must be shipped by LTL Carrier.

**SPECIFICATIONS**

Air Flow ..... 400 CFM  
 Capacity ..... Cooling - 25,000 BTU/Hr with 36°F (6,300 kcal/h with 2.2°C) refrigerant temp. and 80°F (26.7°C) wet bulb entering air  
 Heating - 45,000 BTU/Hr @ 100°F (11,340 kcal/h @ 37.8°C) air temp. rise  
 Current Draw ..... 38.2 amps @ 13.6 VDC (includes 4 amps for A/C clutch)  
 19.1 amps @ 27.2 VDC (includes 2 amps for A/C clutch)  
 Weight ..... 90 lbs. (41 kg)

**OPTIONS**

**10-0026** ..... Horizontal  
**10-9936** ..... Vertical  
 Remote Mount Filter



**10-0045**  
 Fresh Air Filter Box

**10-0032** ..... 12 volt  
**10-0033** ..... 24 volt  
 Inline Booster Pressurizer



**10-0050**  
 Stiffener Brackets

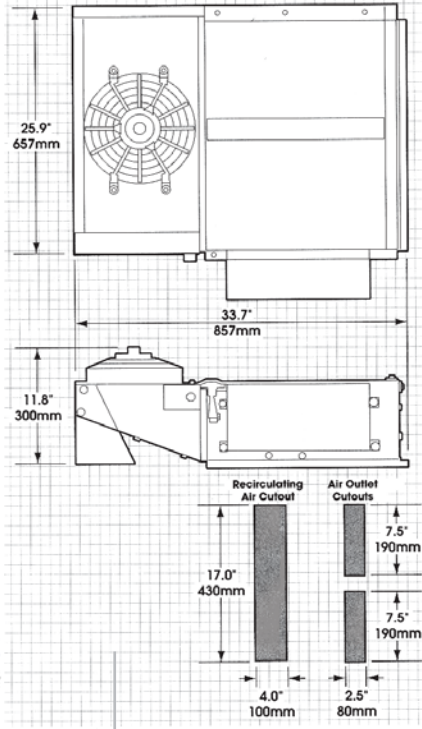

ROOFTOP

**SERVICE PARTS**

	<b>Part No.</b>		<b>Part No.</b>
Blower Wheel, CCW .....	<b>3748</b>	Louver - 4.5" diameter .....	<b>1730</b>
Blower Wheel, CW .....	<b>3747</b>	Motor 12v .....	<b>3322</b>
Circuit Breaker, 20amp - 24v .....	<b>1216</b>	Motor 24v .....	<b>3472</b>
Circuit Breaker, 35amp - 12v .....	<b>1219</b>	Receiver Drier .....	<b>7123</b>
Condenser .....	<b>6044</b>	Relay - 12v .....	<b>1261</b>
Evaporator .....	<b>6540</b>	Relay - 24v .....	<b>1262</b>
Expansion Valve .....	<b>1600</b>	Resistor .....	<b>1220</b>
Fan Motor Assm - 12v (12" dia.) .....	<b>3595</b>	Switch, Fan ON-ON-ON .....	<b>1028</b>
Fan Motor Assm - 24v (12" dia.) .....	<b>3596</b>	Switch, High Pressure .....	<b>1487</b>
Filter, Air Recirculation .....	78R-5370	Switch, Low Pressure .....	<b>1399</b>
Heater Core .....	76R-1860	Switch, Mode ON-OFF-ON .....	<b>1060</b>
Heater Valve .....	<b>2280</b>	Thermostatic Sw. (part of elec panel assm) .	<b>1332</b>
Knob, Control .....	<b>1271</b>		

# A/C & HEATER UNITS

## FACTORY TYPE — DROP-IN EVAPORATOR KIT

FREIGHTLINER, FORD, STERLING - CARGO SERIES TRUCKS 1990 and ON

An integrated air conditioning package for the LCF Freightliner, Ford/Sterling Cargo applications. The heater/air conditioning kit replaces the existing factory heater and out performs any other air conditioning option available. The kit includes everything for a complete installation.



### 10-9440 System Kit Includes:

- Binary Switch
- Condenser
- Drier
- Heater A/C Unit
- Installation Kit
- Rotary Cable Controls

### A/C Unit Also Requires:

- A/C Compressor
- Engine Compressor Bracket Kit

### PART NO.

**10-9440** ..... Heater/Air Conditioner - 12v

### SHIPPING NOTICE

This unit can be shipped by UPS.  
(shipped in 3 separate boxes)

### SPECIFICATIONS

Air Flow ..... 260 CFM  
 Capacity ..... Cooling - 20,000 BTU/Hr with 36°F (kW6.82 with 2.2°C) refrigerant temp. and 80°F (26.7°C) wet bulb entering air  
 Heating - 34,000 BTU/Hr @ 100°F (kW9.67 @ 37.8°C) air temp. rise  
 Current Draw ..... 20 amps @ 13.6 VDC  
 Weight ..... 41 lbs. (19 kg)

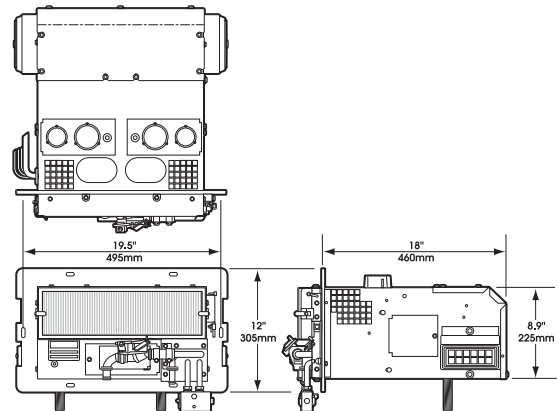

### SERVICE PARTS

	<u>Part No.</u>
Blower Motor Assy. - 12v .....	<b>3980</b>
Condenser .....	<b>6310</b>
Evaporator .....	RD2-3425-0
Expansion Valve .....	<b>1600</b>
Filter .....	<b>9945</b>
Receiver Drier .....	<b>7126</b>
Binary Switch .....	<b>1512</b>
Thermostatic Switch .....	<b>1332</b>

**Not Sure What To Order?  
We Can Help . . .**

See the A/C System  
Configuration Worksheet  
on the last page of this catalog.



## FACTORY TYPE — DROP-IN EVAPORATOR KIT

### FORD "L" SERIES • CONVENTIONALS

The 10-9729 evaporator kit for the Ford "L" Series takes advantage of the existing O.E.M. housing and blower system. The complete system includes condenser, evaporator, hose kit and installation kit to make an easy and complete installation.

**NOTE: DOES NOT FIT FORD "AEROMAX"**

**PART NO.**

**10-9729<sup>1</sup>** ..... 1991-1996  
**10-9730<sup>2</sup>** ..... \*1997- On  
 \*(Limited Availability)

**SHIPPING NOTICE** 

- 1) Due to size and weight, this unit must be shipped by LTL Carrier.
- 2) This unit can be shipped by UPS.  
*(shipped in 3 separate boxes)*



**SPECIFICATIONS**

Capacity ..... Meets OEM manufacturer's specifications

**System Kits Includes:** Kits use high-efficiency style condenser.

- Drop-in Evaporator
- Thermostat & Expansion Valve
- Refrigerant Hose & Fittings
- High Capacity Accumulator
- Wiring Harness
- Condenser
- Installation Hardware

**SERVICE PARTS**

Accumulator .....	<b>7406</b>
Condenser (1997-on) .....	<b>6314</b>
Condenser (1991-96) .....	<b>6068</b>
Evaporator .....	<b>6514</b>
Orifice Tube .....	<b>1651</b>

**Part No.**

**A/C Unit Requires:**

- A/C Compressor
- Engine Compressor Bracket Kit

FACTORY TYPE

## FACTORY TYPE — DROP-IN EVAPORATOR KIT

### NAVISTAR "S" • 4000, 7000, 8000 SERIES • TRUCKS 1995-2002

The 10-9275 drop-in evaporator kit takes advantage of the OEM housing and blower motor assembly, R134a compatible.

**PART NO.**

**10-9275**

**SHIPPING NOTICE**

This unit can be shipped by UPS.  
*(shipped in 3 separate boxes)*

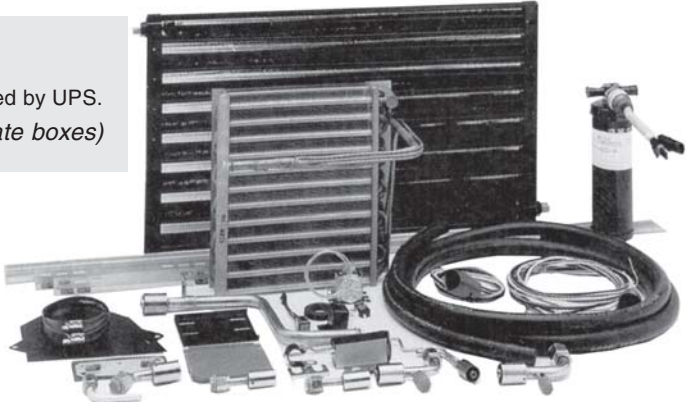

**SPECIFICATIONS**

Capacity ..... Meets OEM manufacturer's specifications

**10-9275 System Kit Includes:**

- Drop-in Evaporator
- Thermostat & Expansion Valve
- Refrigerant Hose & Fittings
- High Capacity Receiver Drier
- Trinary Protection Switch
- Wiring Harness
- Condenser
- Installation Hardware

**SERVICE PARTS**

Condenser .....	<b>6034</b>
Evaporator .....	<b>RD2-2905-0</b>
Expansion Valve .....	<b>1648</b>
Receiver Drier .....	<b>7155</b>
Thermostatic Switch .....	<b>1332</b>
Trinary Switch .....	<b>1565</b>

**Part No.**

**A/C Unit Requires:**

- A/C Compressor
- Engine Compressor Bracket Kit

# A/C & HEATER UNITS

## FACTORY TYPE — UNDER DASH

### MACK "R" MODEL CABS

The 10-9725 heater/air conditioner is without question the best unit available for all Mack "R" model cabs. It can be installed using existing mounting points in all R, U, DM, RL/RS and RW cabs. Features include high performance, factory installed look and a completely new air control system.



**A/C Unit Requires:**

- A/C Compressor
- Hose Kit #9850
- Engine Compressor Bracket Kit
- Condenser
- Condenser Brackets



FACTORY TYPE

**PART NO.**

- 10-9725** ..... Grey - 12v
- 10-9726** ..... Beige - 12v

**SHIPPING NOTICE**

This unit can be shipped by UPS.

**SPECIFICATIONS**

- Air Flow ..... 250 CFM
- Capacity ..... Cooling - 20,000 BTU/Hr with 36°F (5,040 kcal/h with 2.2°C) refrigerant temp. and 80°F (26.7°C) wet bulb entering air  
Heating - 27,000 BTU/Hr @ 100°F (6,804 kcal/h @ 37.8°C) air temp. rise
- Current Draw ..... 14 amps @ 13.6 VDC
- Weight ..... 34 lbs. (15 kg)

**Not Sure What To Order?  
We Can Help . . .**

**See the A/C System  
Configuration Worksheet  
on the last page of this catalog.**

**SERVICE PARTS**

	<u>Part No.</u>		<u>Part No.</u>
Air Actuator Assembly (2) .....	<b>2014</b>	Louver .....	72R-2000
Blower Wheel .....	<b>3650</b>	Louver - A/C (2) .....	<b>1710</b>
Cable, Control .....	<b>2531</b>	Louver (2-1/2") .....	72R-2550
Evaporator .....	<b>6580</b>	Micro Switch .....	<b>1240</b>
Expansion Valve .....	<b>1600</b>	Motor - 12v .....	<b>3044</b>
Heater Core .....	<b>6815</b>	Resistor .....	<b>1220</b>
Heater Valve .....	<b>2210</b>	Switch, Fan .....	<b>1050</b>
Knob (3) .....	71R-4035	Thermostatic Switch .....	<b>1332</b>

# A/C & HEATER UNITS

## FACTORY TYPE — IN DASH

NAVISTAR "S" • 4000, 7000, 8000 SERIES • TRUCKS 1983-1994

The 10-9723 performance and features go beyond anything offered in-dash for all "S" series and new conventional vehicles. With styling that matches the factory dash, the 10-9723 includes "Max A/C" and "Defrost Interlock" features not offered by any other Navistar conventional "S" series or 4000, 7000, and 8000 series systems. The 10-9723 mounts directly to the firewall and mates to existing inlet and outlet ducting.



**10-9723 System Kit Includes:**

- Heater A/C Unit
- Heater Hose & Water Valve
- Refrigerant Hose & Fittings
- High Capacity Receiver Drier
- Trinary Protection Switch
- Wiring Harness
- Condenser
- Installation Hardware

**A/C Unit Requires:**

- A/C Compressor
- Engine Compressor Bracket Kit

<p><b>PART NO.</b> <b>10-9723</b> ..... 12v</p>	<p><b>SHIPPING NOTICE</b> This unit can be shipped by UPS. <i>(shipped in 4 separate boxes)</i></p>
---	---

**SPECIFICATIONS**

Air Flow ..... 265 CFM  
 Capacity ..... Cooling - 22,400 BTU/Hr with 36°F (5,645 kcal/h with 2.2°C) refrigerant temp. and 80°F (26.7°C) wet bulb entering air  
 Heating - 29,700 BTU/Hr @ 100°F (7,484 kcal/h @ 37.8°C) air temp. rise  
 Current Draw ..... 19.5 amps @ 13.6 VDC (includes 4 amps for A/C clutch)  
 Weight ..... 48 lbs. (22 kg)

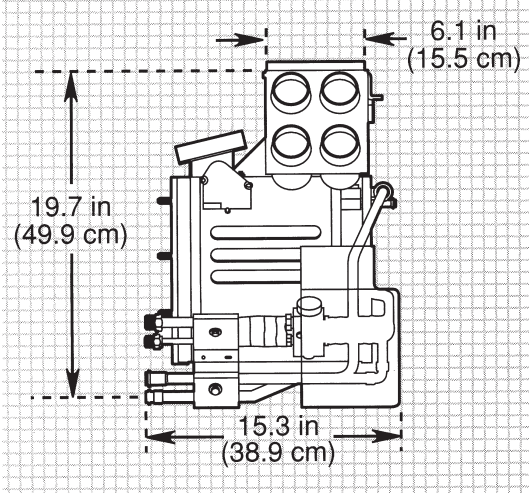

**SERVICE PARTS**

	<u>Part No.</u>
Blower Motor - 12v .....	<b>3034</b>
Blower Wheel .....	<b>3750</b>
Condenser .....	<b>6310</b>
Evaporator .....	<b>6537</b>
Expansion Valve .....	<b>1600</b>
Heater Core .....	<b>6944</b>
Receiver Drier .....	<b>7156</b>
Trinary Switch .....	<b>1565</b>
Thermostatic Switch .....	<b>1332</b>

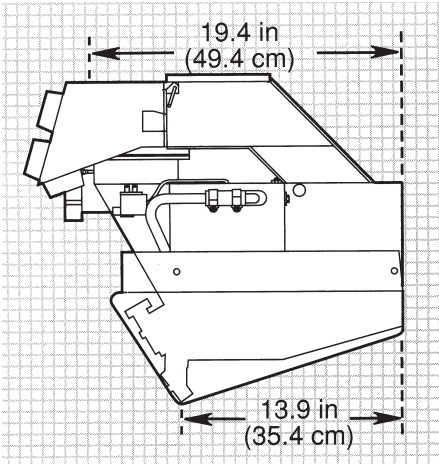

FACTORY TYPE

# A/C & HEATER UNITS

## FACTORY TYPE — IN DASH

FORD F 250HD, 350, 450, 550, 600, 750, 800

**Not Sure What To Order?  
We Can Help . . .**

See the A/C System  
Configuration Worksheet  
on the last page of this catalog.



(typical illustration)

FACTORY TYPE

### PART NO.

**10-9302** ..... F250HD / F550 .....2004-1999

**10-9303** ..... F600 / F750 .....2003-2000

**10-9301** ..... F600 / F800 ..... 1998-1993

### SHIPPING NOTICE

This unit can be shipped by UPS.

### A/C Unit Requires:

- Basic Kit Package
- Compressor
- Engine Compressor Bracket Kit
- Additional components required, call for specific info when ordering.

## FACTORY TYPE — IN DASH

TOPKICK / KODIAK

### PART NO.

**10-9321** ..... 2005-2003

**10-9320** ..... 2002-1990

### SHIPPING NOTICE

This unit can be shipped by UPS.

### A/C Unit Requires:

- Basic Kit Package
- Compressor
- Engine Compressor Bracket Kit
- 2002-1990 models not equipped with factory louvers, may require additional parts







## HOSE INSTALLATION KITS

### FOR ALL UNITS w/RADIATOR OR REMOTE MOUNTED CONDENSER

Part No.	Hose Length & Size	Includes
<b>9850</b> (with Atco type fittings)	18 ft., #6 & #10, 6 ft., #8	All fittings with R134a service ports, high and Low pressure switches, drier and Mounting bracket, Assortment of hose ties and Rubber clamps.
<b>9850EZ</b> (with EZ Clip type fittings)		Same as above with EZ Clip pliers



### FOR ROOF UNITS ONLY

Part No.	Hose Length & Size	Includes
<b>9855</b> (with Atco type fittings)	20 ft., #8 & #10	Fittings (with R134a Service Ports)
<b>9855EZ</b> (with EZ Clip type fittings)		Same as above with EZ Clip pliers



## CONDENSERS — Multi-Flow Aluminum Heavy Duty RetroFit



Frame is designed for numerous mounting locations



Multi-Flow Cross Section

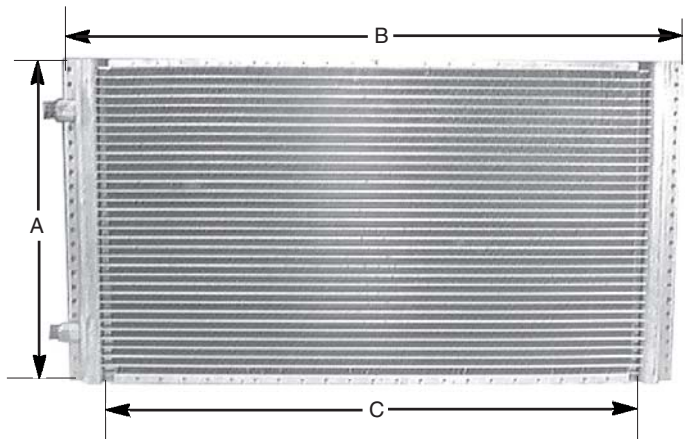

**4 Pass Coil**  
Male Insert O'ring Fittings  
High density fin count produces exceptional heat transfer

PART#	A	B	C	Width	BTU's
<b>6302</b>	10 3/4	25 3/4	22 5/8	1 3/16	14405
<b>6304</b>	12	21 3/4	18 13/16	1 3/16	12940
<b>6306</b>	12	25 3/4	22 13/16	1 3/16	15965
<b>6324</b>	14	14	11 5/16	3/4	n/a
<b>6325</b>	14	18	16 1/4	3/4	n/a
<b>6308</b>	14	21 3/4	18 13/16	1 3/16	15230
<b>6310</b>	14	25 3/4	22 13/16	1 3/16	18476
<b>6312</b>	15 1/2	29 5/8	26 11/16	1 3/16	24880
<b>6326</b>	19 1/4	29 5/8	26 3/4	3/4	n/a
(bracket built into condenser)					
<b>6314</b>	19 9/16	29 5/8	28 11/16	1 3/16	31206

## Condenser Bracket Kits

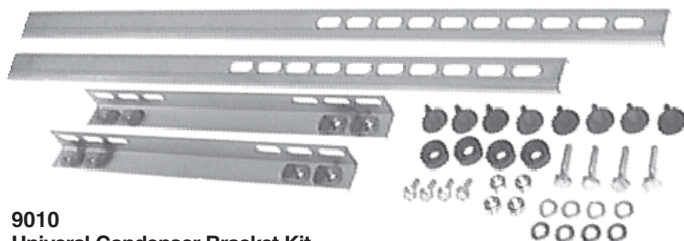

**9010**  
**Universal Condenser Bracket Kit**  
Attaches directly to condenser

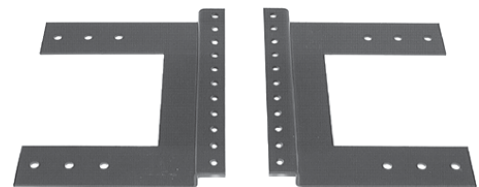

**9013**  
**Multi-Flow Condenser Brackets**  
Attaches directly to aluminum multi-flow condensers (sold in pairs)

# A/C & HEATER UNITS

## PRESSURIZER / BOOSTER BLOWER

CONSTRUCTION • MINING • AGRICULTURE

Attaching directly to the 10-0026 and 10-9936 remote mount filters (shown below), the Booster Blower forces dust free air into the cab through our heater and air conditioner units.



**PART NO.**

**10-0032** ..... 12v

**10-0033** ..... 24v

**SPECIFICATIONS**

Air Flow ..... 140 CFM (283 m<sup>3</sup>/h) with filter,  
230 CFM (391 m<sup>3</sup>/h) without filter

Current Draw ..... 10.2 amps @ 13.6 VDC  
6 amps @ 27.2 VDC

Dimensions ..... 4" Inlet 3" Outlet

Motor/Fan ..... One 12VDC, single speed (24VDC available)

Weight ..... 7 lbs. (3 kg)

**SERVICE PARTS**

	<b>Part No.</b>
Blower Moter - 12v .....	<b>3130</b>
Blower Moter - 24v .....	<b>3003</b>
Blower Wheel .....	<b>3625</b>

UNITS

## REMOTE MOUNT FILTERS (used with Pressurizer / Booster Blower)

**BACKPACK MOUNT**

**10-9925**

9" x 16" long  
(228mm x 464mm)



**REPLACEMENT PARTS**

	<b>Part No.</b>
Filter .....	<b>9928</b>
Hood .....	<b>10-0080</b>
Band .....	<b>10-0081</b>
Rubber Elbow .....	<b>10-0082</b>

**HORIZONTAL MOUNT**

**10-0026**

10 1/4" x 18" long  
(260mm x 457mm)



**REPLACEMENT PARTS**

	<b>Part No.</b>
Filter .....	<b>10-9929</b>
Hood .....	<b>10-0085</b>
Band .....	<b>10-0086</b>

**VERTICAL MOUNT**

**10-9936**

10 1/4" x 23 3/4" long  
(260mm x 503mm)



**REPLACEMENT PARTS**

	<b>Part No.</b>
Filter .....	<b>10-9929</b>
Band .....	<b>10-0086</b>



## CONDENSER UNIT — REMOTE MOUNT

CONSTRUCTION • MINING • AGRICULTURAL

A versatile remote mount condenser that can be installed on top of a horizontal surface or hung below a roof or floor panel. Suitable for use in off road applications or on medium duty trucks or specialty vehicles where a radiator mount or roof-top condenser cannot be used.



**PART NO.**

- 10-9350** ..... 12v (with In-line drier)
- 10-9351** ..... 24v (with In-line drier)

**SHIPPING NOTICE**

This unit can be shipped by UPS.

**SPECIFICATIONS**

- Capacity ..... 30,000 BTU/Hr (6,804 kcal/h)
- Current Draw ..... 12.3 amps @ 13.6 VDC (includes 4 amps for A/C clutch) 6.17 amps @ 27.2 VDC (includes 2 amps for A/C clutch)
- Fan ..... 10-inch diameter fan with single speed long life motor
- Weight ..... 45 lbs. (16.8 kg)

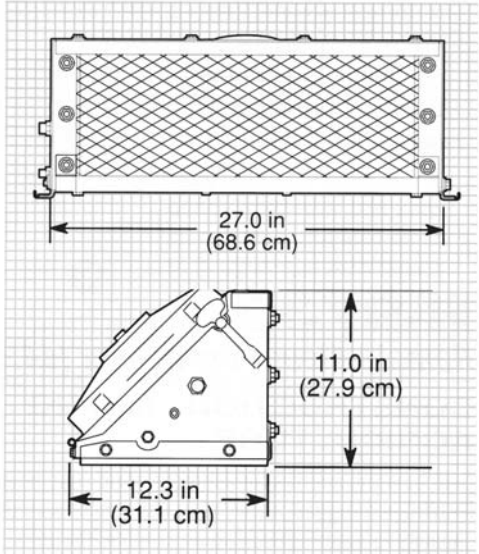

REMOTE

**OPTIONS**

**10-0065**  
Shock Mount Assembly  
(2 required)

**10-0066**  
Condenser Mount Bracket Kit

**SERVICE PARTS**

	<b>Part No.</b>
Binary Switch .....	<b>1510</b>
Condenser .....	<b>6271</b>
Diode .....	71R-1900
Fan .....	<b>3810</b>
Moisture Indicator .....	<b>4150</b>
Motor - 12v .....	<b>3512</b>
Motor - 24v .....	<b>3514</b>
Receiver Drier .....	<b>7502</b>
Relay - 12v .....	<b>1261</b>
Relay - 24v .....	<b>1262</b>

**Not Sure What To Order?  
We Can Help . . .**

See the A/C System  
Configuration Worksheet  
on the last page of this catalog.



## CONDENSER UNIT — REMOTE MOUNT

CONSTRUCTION • MINING • AGRICULTURAL

Built to withstand the punishment of off-road environments, the 10-9375 is a rugged, heavy duty condenser with the tremendous capacity to support two cab air units. Rubber shock mounts absorb vibration while coated heavy guage steel encases the working components. The 10-9375 contains a binary system protection switch attached to a high capacity receiver drier. Two sealed permanent magnet fan motors provide extended life and help to minimize down time. If service is necessary, rubber hood latches provide simple access to all serviceable components.



**PART NO.**

**10-9375** ..... 12v  
**10-9376** ..... 24v

**SHIPPING NOTICE** 

Due to size and weight, this unit must be shipped by LTL Carrier.

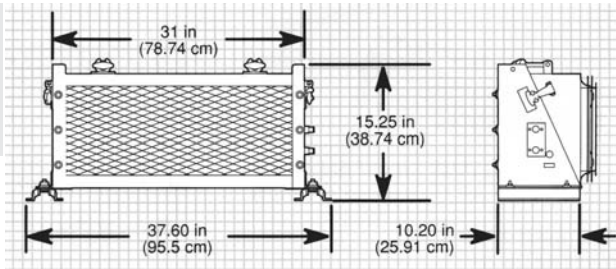

REMOTE

**SPECIFICATIONS**

- Air Flow ..... 1500 CFM
- Capacity ..... 44,500 BTU/Hr (11,214 kcal/h)
- Current Draw ..... 26 amps @ 13.6 VDC (includes 4 amps for A/C clutch)  
 13 amps @ 27.2 VDC (includes 2 amps for A/C clutch)
- Fans ..... Two 10" diameter bladed fans
- Motors ..... Two single speed, long life sealed with pre-lubricated bearings
- Weight ..... 74 lbs. (33.6 kg)

**OPTIONS**

**10-0065**  
 Shock Mount Assembly

**SERVICE PARTS**

	<b>Part No.</b>
Condenser .....	<b>6041</b>
Fan Blade (2) .....	<b>3810</b>
Fan Guard (2) .....	RD-5-3894-1
Fitting Bracket Assembly .....	RD-4-3804-0
Motor - 12v (2) .....	<b>3512</b>
Motor - 24v (2) .....	<b>3514</b>
Receiver Drier .....	<b>7156</b>
Shock Mount (2) .....	<b>10-0065</b>
Switch, Pressure, Binary .....	<b>1500</b>

**Not Sure What To Order?  
 We Can Help . . .**

**See the A/C System  
 Configuration Worksheet  
 on the last page of this catalog.**

# A/C & HEATER UNITS

## CONDENSER UNIT — ROOFTOP MOUNT

HEAVY & MEDIUM DUTY TRUCKS • CONSTRUCTION • AGRICULTURAL

The 10-9385 is the optimal rooftop condenser design. A light weight, compact, and high capacity unit with a styled low profile that fits the aerodynamic vehicle designs of today. A sloping front provides clearance for marker lights while creating effective air flow when roof space is minimal or air shields are used.

**Not Sure What To Order?  
We Can Help . . .**

See the A/C System  
Configuration Worksheet  
on the last page of this catalog.



Condenser Only not a complete A/C Unit

### PART NO.

**10-9385** ..... 12v  
**10-9386** ..... 24v

### SHIPPING NOTICE



Due to size and weight, this unit must be shipped by LTL Carrier.

### SPECIFICATIONS

Air Flow ..... 1500 CFM  
Capacity ..... 24,000 BTU/Hr (6,048 kcal/h)  
Current Draw ..... 12 amps @ 13.6 VDC (includes 4 amps for A/C clutch) 6 amps @ 27.2 VDC (includes 2 amps for A/C clutch)  
Condenser Coil ..... The coil is aluminum fin and copper tube construction, this material selection, which includes a tube of .022" (6 cm) wall thickness, results in an effective, lightweight rugged coil.  
Motor ..... The motor is a permanent magnet type selected for its extended life. The motor is sealed and a slinger ring and hub cap have been added for weather protection. The fan is aluminum with a heavy duty spider and riveted blades.  
Weight ..... 23 lbs. (10.5 kg)

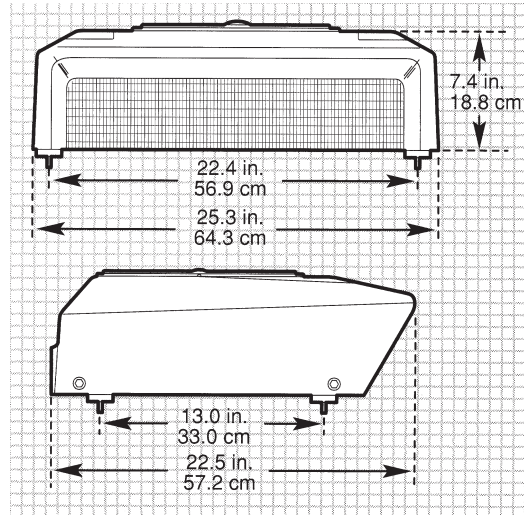

### OPTIONS

**10-0071**  
Bug Screen

**10-0072**  
Winter Cover

**10-0073** ..... 12v  
**10-0074** ..... 24v  
Receiver Drier Kit

### SERVICE PARTS

Part No.	Part No.
Condenser (except w/4 rows) ..... 77R-0600	Receiver Drier (optional models only) ..... <b>7128</b>
Condenser (w/4 rows) ..... <b>6063</b>	Receiver Drier ..... <b>7126</b>
Diode ..... 71R-1900	Receiver Drier (optional models) ..... RD-5-6544-1
Fan ..... <b>3810</b>	Relay - 12v ..... <b>1261</b>
Motor - 12v ..... <b>3978</b>	Relay - 24v ..... <b>1262</b>
Motor - 24v ..... <b>3514</b>	Switch, Trinary ..... <b>1560</b>
Pressure Switch - High ..... <b>1487</b>	
Pressure Switch - Low ..... <b>1447</b>	



## CONDENSER UNIT — ROOFTOP MOUNT

HEAVY & MEDIUM DUTY TRUCKS • CONSTRUCTION • AGRICULTURAL

The latest in design technology was used in developing the 10-9395. From its modern aerodynamic look to its high capacity, the 10-9395 outperforms any unit in its class. Under the cover, heavy duty construction assures that the demands of the class 8 marketplace are met.

**Not Sure What To Order?  
We Can Help . . .**

**See the A/C System  
Configuration Worksheet  
on the last page of this catalog.**



Condenser Only not a complete A/C Unit

<b>PART NO.</b>	<b>SHIPPING NOTICE</b>
<b>10-9395</b> ..... 12v	This unit can be shipped by UPS.
<b>10-9396</b> ..... 24v	

**SPECIFICATIONS**

- Air Flow ..... 970 CFM
- Capacity ..... 38,800 BTU/Hr (9,576 kcal/h)
- Current Draw ..... 15 amps @ 13.6 VDC (includes 4 amps for A/C clutch) 8.5 amps @ 27.2 VDC (includes 2 amps for A/C clutch)
- Motor/Fan ..... Two 11-inch (27.9 cm) diameter pancake motor assembly
- Weight ..... 30 lbs. (14 kg)

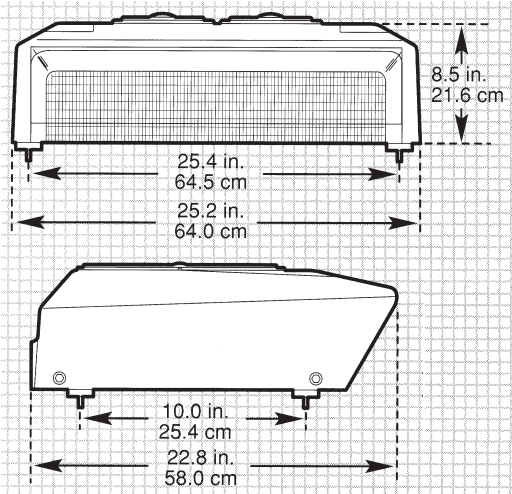

ROOFTOP

<b>OPTIONS</b>	<b>Part No.</b>
Bug Screen	10-0075

**SERVICE PARTS**

	<b>Part No.</b>
Condenser .....	77R-0630
Fan/Motor Assembly - 12v (2) .....	73R-8572
Fan/Motor Assembly - 24v (2) .....	73R-8574

# A/C & HEATER UNITS

## CONDENSER UNIT — ROOFTOP MOUNT

FIRE TRUCKS • CRASH & RESCUE VEHICLES • DUAL EVAPORATORS

The 10-9398 offers amazing performance for a light weight dual fan power condenser. Its high capacity gives the installer a condenser to match with high performance evaporators or dual evaporator systems. The latest motor technology allows for the lowest profile possible while maintaining high output.

**Not Sure What To Order?  
We Can Help . . .**

See the A/C System  
Configuration Worksheet  
on the last page of this catalog.



Condenser Only not a complete A/C Unit

ROOFTOP

**PART NO.**

**10-9398** ..... 12v  
**10-9399** ..... 24v

**SHIPPING NOTICE**



Due to size and weight, this unit must be shipped by LTL Carrier.

**SPECIFICATIONS**

Air Flow ..... 2,011 CFM  
Capacity ..... 45,200 BTU/Hr (11,340 kcal/h)  
Current Draw ..... 30.3 amps @ 13.6 VDC  
Motor/Fan ..... Two 16-inch diameter pancake motor assembly  
Weight ..... 85 lbs. (38.6 kg)

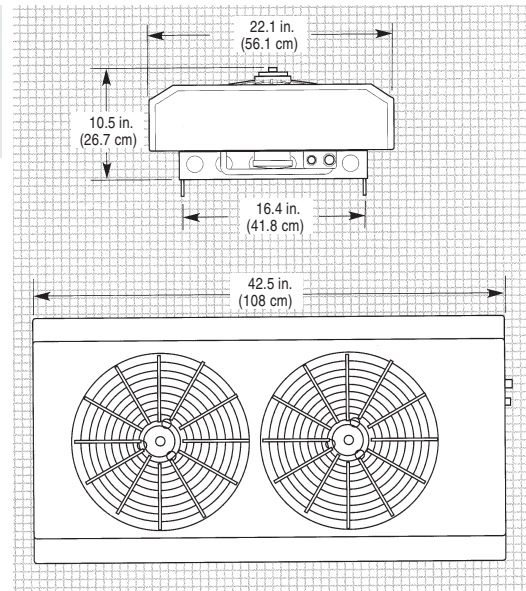

**SERVICE PARTS**

	<b>Part No.</b>
Coil Assembly .....	77R-0990
Fan, Motor Assembly 12v (2) .....	<b>3568MP</b>
Fan, Motor Assembly 24v (2) .....	<b>3569MP</b>
Receiver Drier .....	<b>7555</b>
Relay 12v .....	<b>1261</b>
Relay 24v .....	<b>1262</b>
Switch, High Side .....	RD-5-9267-0

## AUXILIARY HEATERS

TRUCKS • BOATS • RECREATIONAL VEHICLES

These auxiliary heaters are among the most versatile and maintenance free units offered in the industry. Round tube and fin design allows these heaters to mount in any position, using the supplied multi-position leg brackets or flush mount frame. The compact size, simple plumbing and high output are ideal in any application.



10-9800

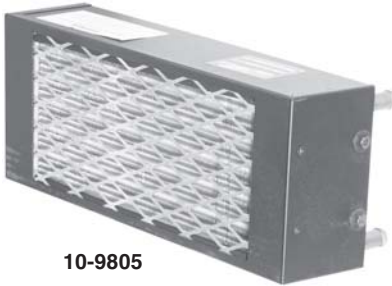

10-9805

<b>PART NO.</b>	SINGLE FAN REAR EXIT 5/8" fittings:	DOUBLE FAN REAR EXIT 5/8" fittings:	SINGLE FAN REAR EXIT 5/8" fittings:
	<b>10-9800</b> ..... (12v) <b>10-9801</b> ..... (24v)	<b>10-9805</b> ..... (12v) <b>10-9806</b> ..... (24v)	<b>10-9809</b> ..... (12v) LOW AMP
<b>PART NO.</b>	3/4" fittings: <b>10-9802</b> ..... (12v)	3/4" fittings: <b>10-9807</b> ..... (12v)	
<b>PART NO.</b>	FLOOR EXIT 5/8" fittings: <b>10-9803</b> ..... (12v)	FLOOR EXIT 5/8" fittings: <b>10-9808</b> ..... (12v)	

**SHIPPING NOTICE**

These auxiliary heaters can be shipped by UPS.

AUXILIARY

**SPECIFICATIONS**

	SINGLE FAN	DOUBLE FAN	SINGLE FAN
Air Flow	150 CFM (255 m³/h)	280 CFM (476 m³/h)	87 CFM (148 m³/h)
Capacity	16,000 BTU/Hr @ 150°F (4,032 kcal/h @ 65.6°C)	30,000 BTU/Hr @ 100°F (7,560 kcal/h @ 37.8°C)	9,000 BTU/Hr @ 100°F (2,268 kcal/h @ 37.8°C)
Current Draw	3.3 amps @ 13.6 VDC 1.7 amps @ 27.2 VDC	6.6 amps @ 13.6 VDC 3.3 amps @ 27.2 VDC	1.3 amps @ 13.6 VDC
Weight	7 lbs. (3 kg)	12 lbs (5.5 kg)	7 lbs

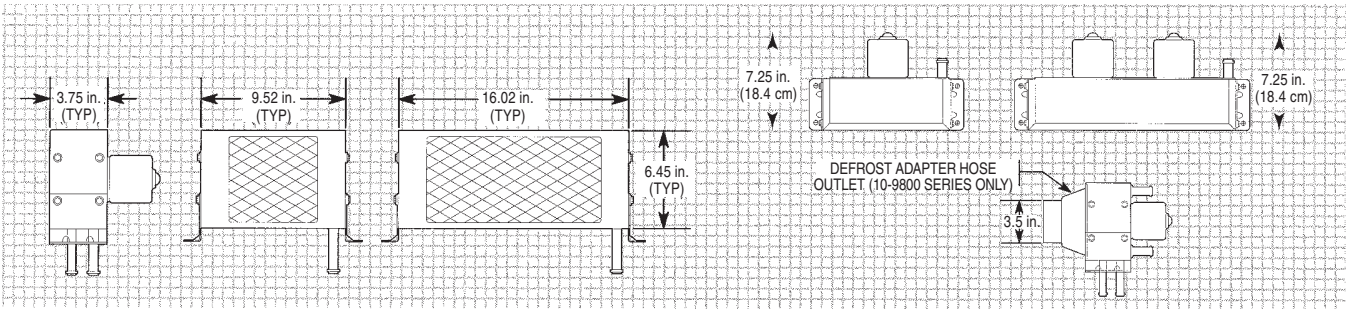

**OPTIONS**

**8800**  
Heater Hose  
(50 ft. #5/8")

**1030**  
Switch, Toggle



**10-0502**  
3-1/2" Defrost Hose Outlet

# A/C & HEATER UNITS

## AUXILIARY HEATERS

TRUCKS • BOATS • RECREATIONAL VEHICLES

These "compact series" heaters feature high velocity and high performance with three speed motors and scroll blower housings. They deliver maximum BTU's with unsurpassed CFM. A defrost hose adapter is available to make ducting air possible.

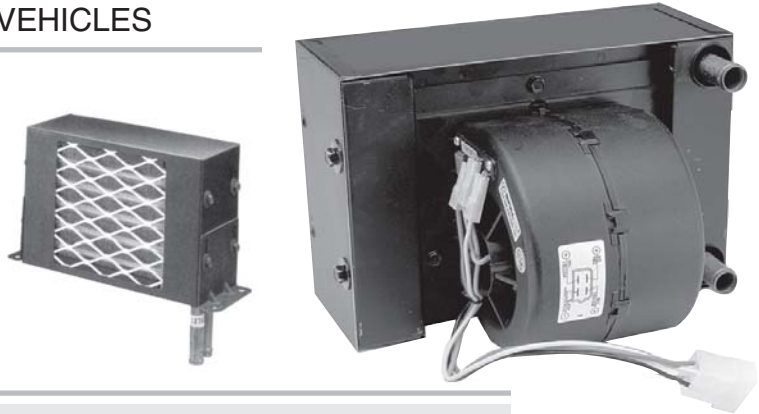

	REAR EXIT 5/8" fittings:	REAR EXIT 3/4" fittings:	FLOOR EXIT 5/8" fittings:
<b>PART NO.</b>	<b>10-9830</b> ..... (12v) <b>10-9831</b> ..... (24v)	<b>10-9832</b> ..... (12v) <b>10-9833</b> ..... (24v)	<b>10-9834</b> ..... (12v)

### SHIPPING NOTICE

These auxiliary heaters can be shipped by UPS.

### SPECIFICATIONS

Air Flow .....	220 CFM (373 m <sup>3</sup> /h)
Capacity .....	20,000 BTU/Hr @ 150°F (5,040 kcal/h @ 65.6°C)
Current Draw .....	4.3 amps @ 13.6 VDC
Weight .....	7 lbs. (3 kg)

### SERVICE PART

Blower Motor 12v..... **3979**

### OPTIONS

**1150**  
Switch  
Rotary



**1272**  
Control Knob



**10-0502**  
3-1/2" Defrost Hose Adapter

## AUXILIARY DOUBLE BLOWER HEATER

TRUCKS • RECREATIONAL VEHICLES

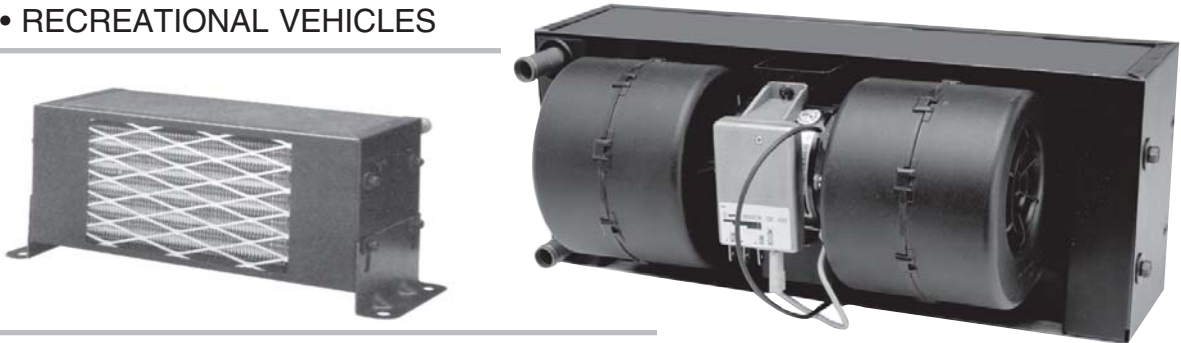

	REAR EXIT	FLOOR EXIT
<b>PART NO.</b>	<b>10-9840</b> ..... (12v) <b>10-9841</b> ..... (24v)	<b>10-9842</b> ..... (12v)

### SHIPPING NOTICE

These auxiliary heaters can be shipped by UPS.

### SPECIFICATIONS

Air Flow .....	435 CFM (373 m <sup>3</sup> /h)
Capacity .....	35,000 BTU/Hr @ 180°F (5,040 kcal/h @ 65.6°C)
Current Draw .....	16 amps @ 13.6 VDC 7 amps @ 27.2 VDC
Weight .....	11 lbs. (3 kg)

### OPTIONS

**1150**  
Switch  
Rotary



**1272**  
Control Knob



**10-0502**  
3-1/2" Defrost Hose Adapter



AUXILIARY HEATERS

FIRE TRUCKS • BUSES • VANS

Designed to fit in small areas, the 10-9872 delivers a lot of BTU's for it's size. Using a pancake fan design, this unit is quiet and moves close to 200 CFM of air. The 10-9872 has versatile mounting, either flat or horizontal.

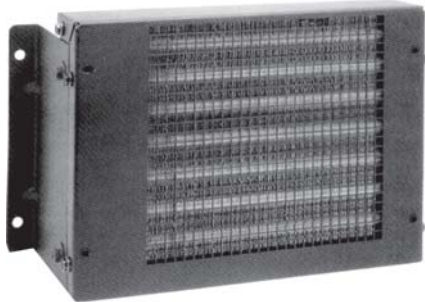

The 10-9872's quiet and powerful pancake fan moves almost 200 CFM of air.

PART NO.

10-9872 ..... 12v

SHIPPING NOTICE

This unit can be shipped by UPS.

SPECIFICATIONS

- Air Flow ..... 194 CFM (330 m<sup>3</sup>/h)
- Capacity ..... 22,970 BTU/Hr @ 180°F  
(5,544 kcal/h @ 82.6°C)
- Current Draw ..... 4.8 amps @ 13.6 VDC
- Weight ..... 10 lbs. (4.5 kg)

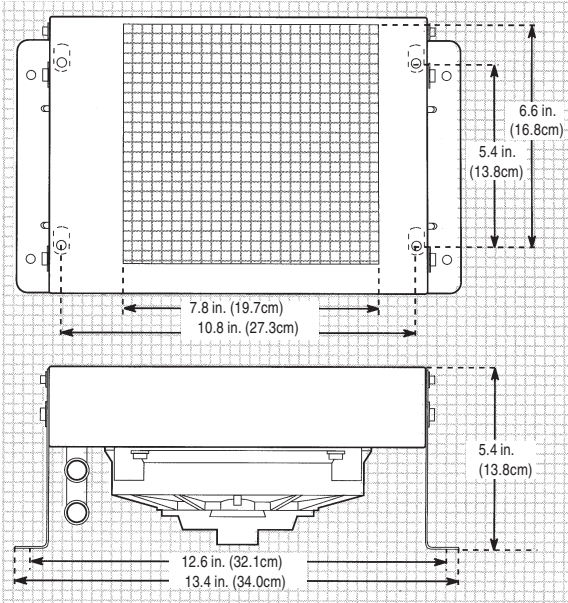

AUXILIARY

# A/C & HEATER UNITS

## AUXILIARY HEATER — DEFROST and OIL COOLER

MARINE USE • CONSTRUCTION • INDUSTRIAL CABS

No other heater offers as many options as the 10-9868. This heater can be used in vehicles with water or air cooled engines (where oil is the heat source.) The compact design, round tube and fin core construction encourage unit mounting in any position while withstanding high operating pressures. The versatile mounting features and defrost attachments are perfect for multi-purpose applications in off-road and construction vehicles. The 10-9868 can also be used as a heat exchanger or oil cooler with its o-ring hose fittings and high pressure core construction.



### PART NO.

**10-9868** ..... 12v

### SHIPPING NOTICE

This unit can be shipped by UPS.

### SPECIFICATIONS

Air Flow ..... 165 CFM (280 m<sup>3</sup>/h)  
 Capacity ..... 17,800 BTU/Hr @ 100°F  
 (4,486 kcal/h @ 37.8°C)  
 Current Draw ..... 6 amps @ 13.6 VDC  
 3 amps @ 27.2 VDC  
 Weight ..... 10.7 lbs. (4.85 kg)

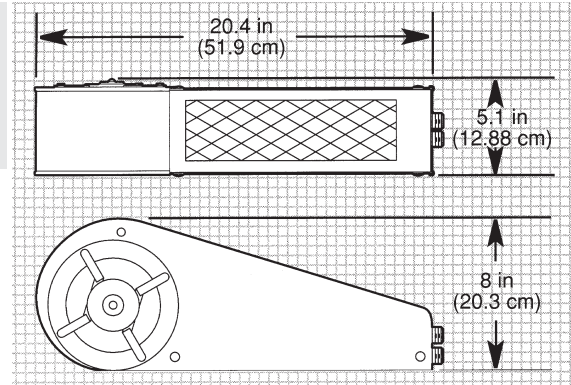

### OPTIONS

**2659** ..... Straight 5/8" hose  
**2662** ..... 90° 5/8" hose  
 Swivel Fittings

**10-0512**  
 2-1/2" Defrost Adapter

**10-0513**  
 3" Defrost Adapter

### SERVICE PARTS

	<b>Part No.</b>
Blower Motor - 12v .....	<b>3072</b>
Blower Motor - 24v .....	<b>3012</b>
Blower Wheel .....	<b>3655</b>
Heater Core .....	76R-0500

AUXILIARY

## AUXILIARY HEATER

FIRE TRUCKS • CRASH & RESCUE VEHICLES • LARGE CABS

The 10-9870 crew cab heater was designed with high performance to be able to heat larger cabs in extreme conditions. Its low profile and heavy duty construction allows this heater to be used in various applications.



**PART NO.**

**10-9870** ..... \*12v  
 \*(Limited Availability)

**SHIPPING NOTICE**

This unit can be shipped by UPS.

**SPECIFICATIONS**

Air Flow ..... 480 CFM (330 m<sup>3</sup>/h)  
 Capacity ..... 49,000 BTU/Hr @ 180°F  
 (12,348 kcal/h @ 82.6°C)  
 Current Draw ..... 5.9 amps @ 13.6 VDC  
 Weight ..... 28 lbs. (4.5 kg)

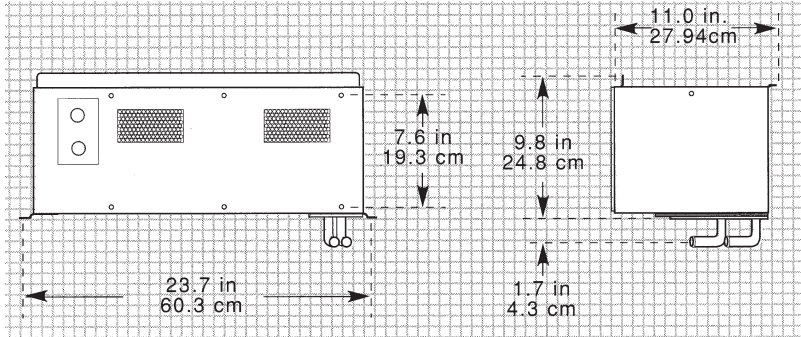

**SERVICE PARTS**

	<b>Part No.</b>
Blower Motor - 12v .....	73R-4122
Blower Wheel (2) .....	<b>3735</b>
Heater Core .....	76R-3920
Heater Valve .....	<b>2282</b>
Knob, Control (temperature) .....	<b>1271</b>
Knob, Control (fan) .....	RD-5-8127-0
Resistor, Speed Control .....	<b>1220</b>
Switch, Rotary 3 speed .....	<b>1150</b>

AUXILIARY

# A/C & HEATER UNITS

## AUXILIARY HEATER

FIRE TRUCKS • BUSES • VANS • CONSTRUCTION • OFF-ROAD

These "compact series" heaters feature high velocity and high performance with three speed motors and scroll blower housings. They deliver maximum BTU's with unsurpassed CFM. A defrost hose adapter is available to make ducting air possible.

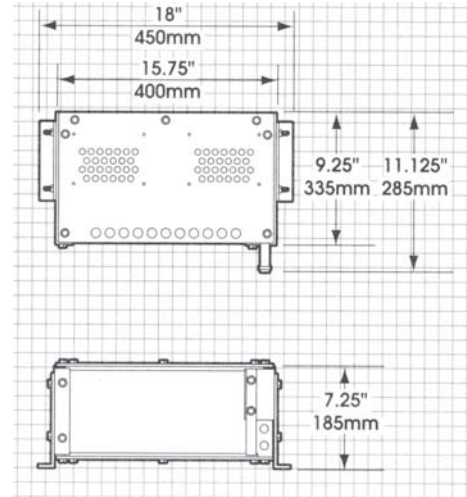

### PART NO.

**10-9880** ..... \*12v  
\*(Limited Availability)

### SHIPPING NOTICE

This unit can be shipped by UPS.

### SPECIFICATIONS

Air Flow ..... 270 CFM (459 m<sup>3</sup>/h)  
Capacity ..... 29,100 BTU/Hr @ 180°F (kw 8.52 @ 82.6°C)  
Current Draw ..... 11.4 amps @ 13.6 VDC  
Weight ..... 14 lbs.

AUXILIARY

## AUXILIARY HEATER

TRUCKS • RECREATIONAL VEHICLES

An extremely compact heater the 10-9890 series offers a highly tooled light weight design. There are three optional "Snap In" outlet configurations available which will allow for various air flow configurations. An additional installation kit which includes mounting hardware and fan switch is also available.

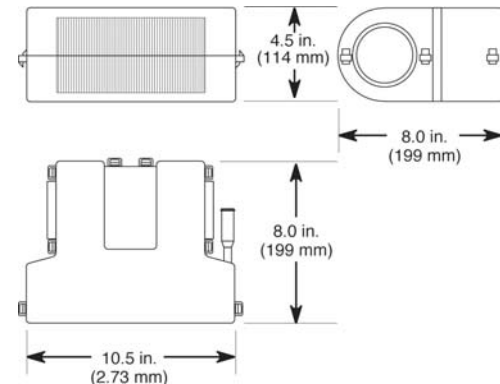

### PART NO.

**10-9890** ..... \*12v  
**10-9891** ..... \*24v  
\*(Limited Availability)

### SHIPPING NOTICE

This unit can be shipped by UPS.

### SPECIFICATIONS

Air Flow ..... 140 CFM (237 m<sup>3</sup>/h)  
Capacity ..... 15,500 BTU/Hr @ 100°F  
(3,779 kcal/h @ 34.8°C)  
Current Draw ..... 7.7 amps @ 13.6 VDC  
Weight ..... 7 lbs. (3 kg)

### OPTIONS

<b>10-0520</b> Installation Kit	<b>10-0521</b> ..... Straight 2-1/2" <b>10-0522</b> ..... 45° 1-3/4" Hose Outlet	<b>10-0523</b> Louvered Outlet
------------------------------------	--	-----------------------------------

## AUXILIARY HEATERS

### Quick Find Chart (Sorted by BTU's)

HEATER #	BTU's	CFM	DINEMSIONS	FAN	VOLT
10-9821	10,000	180	6-3/16 H x 11-3/4 W x 8 D	2 SPD	12
10-9826	12,500	150	7 H x 8 W x 7 D	2 SPD	12
10-9827	12,500	150	7 H x 8 W x 7 D	2 SPD	24
10-9815	13,000	150	7-1/4 H x 7-1/4 W x 7-1/4 D	2 SPD	12
10-9825	21,715	210	4-3/4 H x 11-7/16 W x 11-1/2 D	2SPD	24
10-9816	25,000	250	8-1/4 H x 8-1/4 W x 8-1/4 D	2 SPD	12
10-9817	25,000	250	8-1/4 H x 8-1/4 W x 8-1/4 D	2 SPD	24
10-9819	29,380	244	8-1/4 H x 8-1/8 W x 9 D	2 SPD	12
10-9822	33,000	275	5-1/4 H x 16 W x 8 D	DBL. 3 SPD	12
10-9824	33,000	350	10 H x 16 W x 5-1/4 D	2 SPD	12
10-9823	34,054	265	9-3/16 H x 9-3/16 W x 9-1/2 D	2 SPD	12
10-9820	39,174	375	9-3/4 H x 14-3/4 W x 9-1/2 D	2 SPD	12
10-9818	60,000	500	9 H x 20-1/4 W x 9-1/2 D	DBL. 2 SPD	12

#### 10-9815 CAB HEATER

Height	Width	Diameter
7-1/4" x	7-1/4" x	7-1/4"
BTU/HR .....	13,000	CFM .....
Amp Draw High .....	5	Volt .....
Speed .....	2	Weight ..

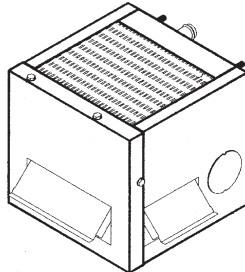

This compact heater is very popular in small cab applications. Hose collars can be added when window defrosting is required. Stud mounts make this unit good for inside firewall mounting.

#### 10-9816 (12v) 10-9817 (24v) CAB HEATER

Height	Width	Diameter
8-1/4" x	8-1/4" x	8-1/4"
BTU/HR .....	25,000	CFM .....
Amp Draw High .....	5	Volt .....
Amp Draw High ...	2.5	Volt .....
Speed .....	2	Weight ..

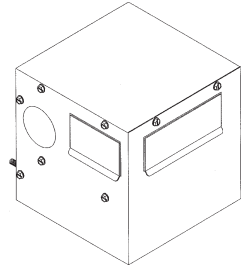

This heater is popular in small cab applications when a higher output heater is called for. Hose collars can be added when window defrosting is required. Stud mounts make this unit good for inside firewall mounting.

#### 10-9818 UNDER SEAT HEATER

Height	Width	Diameter
9" x	20-1/4" x	9-1/2"
BTU/HR .....	60,000	CFM .....
Amp Draw High .....	16	Volt .....
Speed (double) .....	2	Weight ..

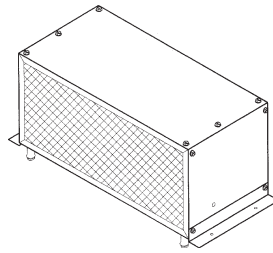

This powerful twin fan underseat heater delivers full 60,000 BTU's. An ideal underseat bus heater.

#### 10-9819 CAB HEATER

Height	Width	Diameter
8-1/4" x	8-1/8" x	9"
BTU/HR .....	29,380	CFM .....
Amp Draw High .....	10	Volt .....
Speed .....	2	Weight ..

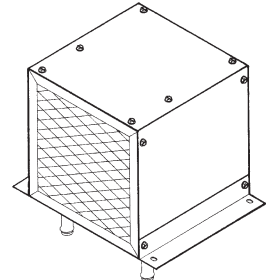

This rugged unit provides excellent heating for the small bus, truck body and R.V. industries.

#### 10-9820 UNDER SEATHEATER

Height	Width	Diameter
9-3/4" x	14-3/4" x	9-1/2"
BTU/HR .....	39,174	CFM .....
Amp Draw High .....	10	Volt .....
Speed .....	2	Weight ..

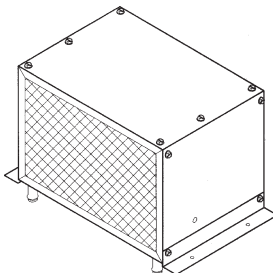

This durable auxiliary heater provides a full 40,000 BTU heating ideal for buses, larger van bodies and heavy equipment.

#### 10-9821 STEPWELL HEATER with Faceplate

Height	Width	Diameter
6-3/16" x	11-3/4" x	8"
BTU/HR .....	10,000	CFM .....
Amp Draw High .....	5	Volt .....
Speed .....	2	Weight ..

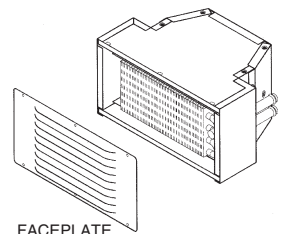

FACEPLATE

This versatile, compact unit delivers heat in a variety of applications from bus stepwell to off highway space heating. Built of heavy gage precoated steel and powder coat finished to hold up to the elements. Mounting provisions on both sides assure maximum installation flexibility.



# A/C & HEATER UNITS

## AUXILIARY HEATERS

### 10-9822 UNDER SEAT HEATER

Height	Width	Diameter
5-1/4" x	16" x	8"
BTU/HR .....	33,000	CFM .....
Amp Draw High ....	14	Volt .....
Speed (double) .....	3	Weight ..
		12 lbs

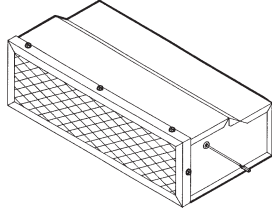

A heavy duty twin blower auxiliary heater designed for use in ambulances, rescue vehicles and heavy equipment.

### 10-9823 UNDER SEAT HEATER

Height	Width	Diameter
9-3/16" x	9-3/16" x	9-1/2"
BTU/HR .....	34,054	CFM .....
Amp Draw High ....	10	Volt .....
Speed .....	2	Weight ..
		15 lbs

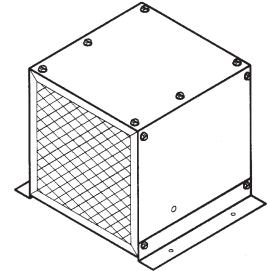

A high output auxiliary heater for use as a rear van body heater and a bus underseat heater.

### 10-9824 HEATER / DEFROSTER

Height	Width	Diameter
10" x	16" x	5-1/4"
BTU/HR .....	33,000	CFM .....
Amp Draw High ....	14	Volt .....
Speed .....	3	Weight ..
		14 lbs

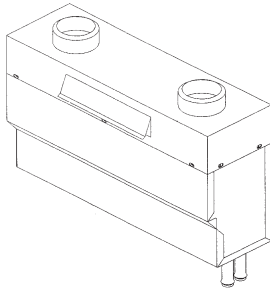

Used in small cabs, this rugged unit provides a door for heat and two 2-1/2 inch collars for either defogging or remote heat runs.

### 10-9825 CAB HEATER

Height	Width	Diameter
4-3/4" x	11-7/16" x	11-1/2"
BTU/HR .....	21,715	CFM .....
Amp Draw High .....	-	Volt .....
Speed .....	2	Weight .....
		-

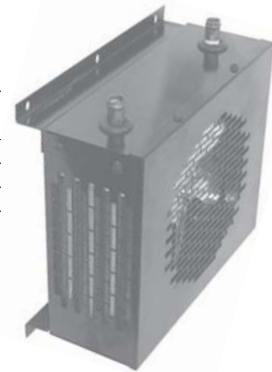

FLOOR OR WALL MOUNT HEATER - Air enters through the top and exhaust out each side or be reversed. Includes 3 position switch, mounting nuts, wiring diagram and installation instructions.



### 10-9826 ..... 12V UNDER SEAT HEATER

Height	Width	Diameter
7" x	7" x	7"
BTU/HR .....	12,500	
CFM .....	150	
Amp Draw High .....	-	
Volt .....	12	
Speed .....	2	
Weight .....	-	

### 10-9827 ..... 24V UNDER SEAT HEATER

Height	Width	Diameter
7" x	7" x	7"
BTU/HR .....	12,500	
CFM .....	150	
Amp Draw High .....	-	
Volt .....	24	
Speed .....	2	
Weight .....	-	

Fully rotational in 90° increments by switching core tube locations. Includes 3 position switch, mounting nuts, wiring diagram and installation instructions.

**ELECTRIC DC HEATERS**

***Infra-Red Quartz Recirculating Forced Air (Fan) Heaters***

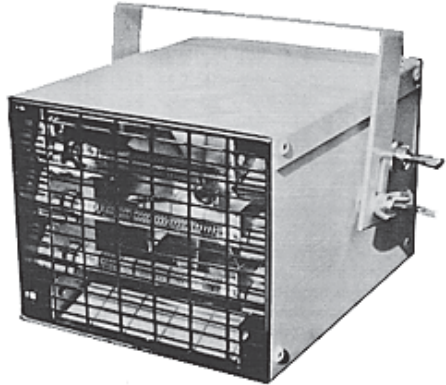

- AUTOMOTIVE
- OFF-ROAD EQUIPMENT
- INDUSTRIAL
- GOLF CARS
- MARINE
- S.T.C. AIRCRAFT\*
- INSTANT HEAT
- U.S.A. MANUFACTURED
- SAFE
- EFFICIENT
- DEPENDABLE
- F.A.A. APPROVED
- ODORLESS
- 2-YEAR WARRANTY

\*Special Order Only on Certified Aircraft

NOTE: As a general rule, alternator must have at least 15 more amps than the heater.  
(ex. 10-9854 requires a minimum 50 amp alternator.)

***AUTOMOTIVE, OFF-ROAD, INDUSTRIAL, GOLF, MARINE & S.T.C. AIRCRAFT (12v-24v)***

PART #	DESCRIPTION	VOLTS (1)	DIMENSIONS	AMPS*	WATTS	BTU'S
10-9850	DC Electric Htr	12v	4" H x 5" W x 6" D	25	355	1212H/800L
10-9853	DC Electric Htr	12v	4" H x 5" W x 6" D	35	497	1696H/1120L
10-9855	DC Electric Htr	12v	4" H x 5" W x 6" D	47	658	2250H/1125L
10-9851	DC Electric Htr	24v	4" H x 5" W x 6" D	25	700	2389H/1577L
10-9852	DC Electric Htr	24v	4" H x 5" W x 6" D	30	840	2867H/1892L
10-9854	DC Electric Htr	24v	4" H x 5" W x 6" D	35	980	3345H/1673L

**NOTES:**

- (1) 12v nominal voltage = 14.2 alternator voltage / 24v nominal voltage = 28 alternator voltage
- Heaters are hard-wired into electrical system (uses 30 or 40 amp fuse).
  - Heaters equipped with High/Low switch on side (can be operated from dash with a push/pull switch).
  - Heaters can be used on FAA approved S.T.C. aircraft (field approval form #337 required).
  - By design, the airflow on these heaters is not as strong as the airflow on the vehicle's O.E. heater.
    - The infrared heat warms exposed flesh, not the air.
    - The convective flow of heat warms the air in the vehicle.

\*Special Order Only on Certified Aircraft

AUXILIARY

# A/C & HEATER UNITS

## School, Shuttle and Transit

### EVAPORATOR — CEILING MOUNT — 35,000 BTU

Manufactured for the transportation industry, the 10-9335 evaporator is designed for free-blow ceiling mount applications. Available in rear, side, or forward mount (must specify when ordering).

#### FEATURES

- Enhanced Performance, Serviceability, and Ease of Installation
- Unique Louver Design Enhances Airflow
- Low Profile Design for Additional Passenger Headroom
- Super High Blower Speed
- Drain Pan Construction Eliminates Condensation Problems
- Return Air Thermostat Maximizes Comfort Level
- Pressure Switches for Maximum Compressor Protection
- Enhanced Copper Tubed and Finned Coil Increases System Performance

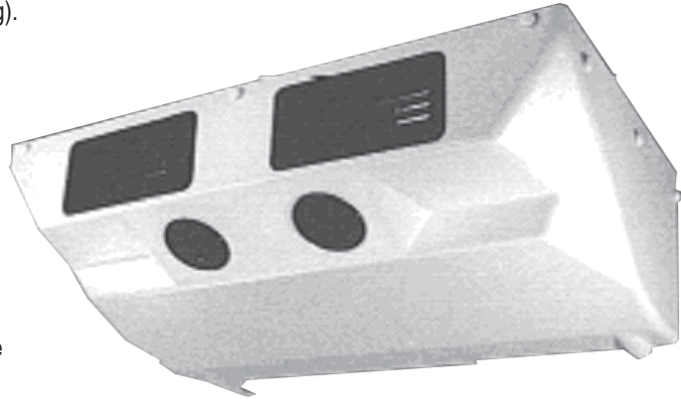

School, Shuttle, Transit

#### PART NO.

**10-9335** ..... Rear/Front  
**10-9335S** ..... Side

#### SHIPPING NOTICE



Due to size and weight, this unit must be shipped by LTL Carrier.

#### A/C UNIT REQUIRES:

- A/C Compressor(s)
- Control Panel# **10-0063**
- Engine Compressor Bracket Kit
- Hose Kit
- Condenser(s)

#### SPECIFICATIONS

Air Flow ..... 700 CFM (1186 m3/hr)  
Amperage Draw ..... 15 Amps @ 13.5 Volts  
Cooling Capacity ..... 35,000 Btu/Hr (8,821 kcal)  
Filter ..... Cleanable Aluminum Mesh  
Mounting Holes ..... 1/2" Dia. (4 Places)  
Voltage ..... 12v  
Weight ..... 37 lbs.

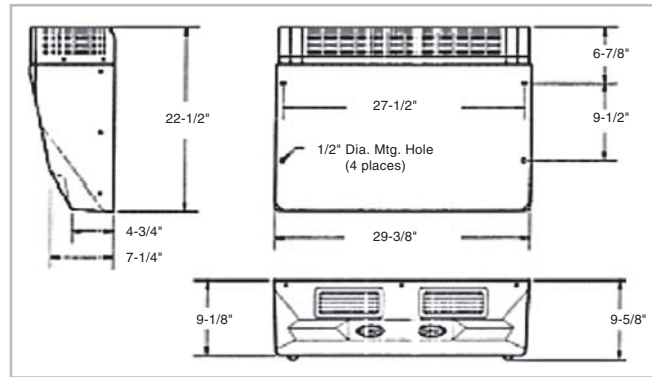

#### OPTIONS - Specify When Ordering

- Air Outlet Louvers ... Adjustable or Fixed
- Cover ..... Grey, White or Beige
- Mounting Position .... Rear, Side, or Forward

**Not Sure What To Order?  
We Can Help . . .**

**Call Our Customer Service  
Toll-free Number for Assistance.**

# A/C & HEATER UNITS

## School, Shuttle and Transit

### EVAPORATOR — CEILING MOUNT — 43,000 and 55,000 BTU

Manufactured for the transportation industry, the 10-9335 evaporator is designed for free-blow ceiling mount applications. Available in rear, side, or forward mount (must specify when ordering).

**FEATURES**

- Enhanced Performance, Serviceability, and Ease of Installation
- Unique Louver Design Enhances Airflow
- Low Profile Design for Additional Passenger Headroom
- Super High Blower Speed
- Drain Pan Construction Eliminates Condensation Problems
- Return Air Thermostat Maximizes Comfort Level
- Pressure Switches for Maximum Compressor Protection
- Enhanced Copper Tubed and Finned Coil Increases System Performance

**A/C UNIT REQUIRES:**

- A/C Compressor(s)
- Control Panel# **10-0063**
- Engine Compressor Bracket Kit
- Hose Kit
- Condenser(s)

**OPTIONS - Specify When Ordering**

- Air Outlet Louvers ..... Adjustable or Fixed
- Cover ..... Grey, White or Beige
- Mounting Position ..... Rear, Side, or Forward

<p><b>PART NO.</b></p> <p><b>10-9343</b> ..... Rear/Front</p> <p><b>10-9343S</b> ..... Side</p>	<p><b>SHIPPING NOTICE</b> </p> <p>Due to size and weight, this unit must be shipped by LTL Carrier.</p>
---	---

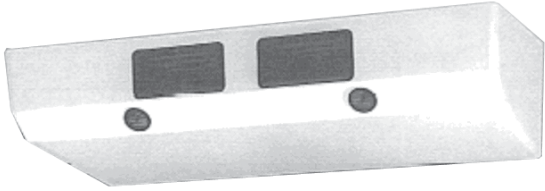

**SPECIFICATIONS**

- Air Flow ..... 800 CFM (1356 m3/hr)
- Amperage Draw ..... 9 Amps @ 13.5 Volts
- Cooling Capacity ..... 43,000 Btu/Hr (10,836 kcal)
- Filter ..... Cleanable Aluminum Mesh
- Mounting Holes ..... 1/2" Dia. (6 Places)
- Voltage ..... 12v
- Weight ..... 61 lbs.

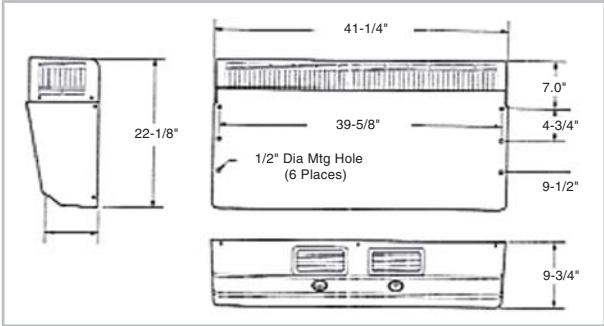

<p><b>PART NO.</b></p> <p><b>10-9355</b> ..... Rear/Front</p> <p><b>10-9355S</b> ..... Side</p>	<p><b>SHIPPING NOTICE</b> </p> <p>Due to size and weight, this unit must be shipped by LTL Carrier.</p>
---	---



**SPECIFICATIONS**

- Air Flow ..... 1600 CFM (2712 m3/hr)
- Amperage Draw ..... 18 Amps @ 13.5 Volts
- Cooling Capacity ..... 55,000 Btu/Hr (13,860 kcal)
- Filter ..... Cleanable Aluminum Mesh
- Mounting Holes ..... 1/2" Dia. (5 Places)
- Voltage ..... 12v
- Weight ..... 67 lbs.

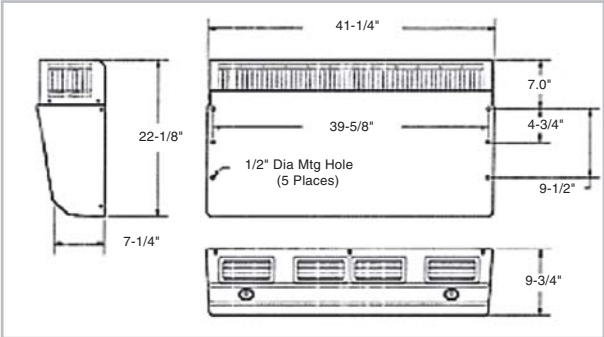

School, Shuttle, Transit

# A/C & HEATER UNITS

## School, Shuttle and Transit

### CONDENSER — SKIRT MOUNT — 60,000 and 78,000 BTU

Manufactured for the transportation industry, the 10-9382 and 10-9383 condensers are designed for skirt mount applications.

#### FEATURES

- Low Profile, High Grade Lightweight Aluminum Construction
- Enhanced Performance, Serviceability, and Ease of Installation
- Integral Sightglass/Filter Drier (16 cu. in.)
- Superior Heat Rejection Resulting In:
  - Lower Evap. Temperature
  - Lower Head Pressure
- 12" Electric Fans for Increased Airflow
- Sealed Motor Design for Long Life
- Enhanced Rifled Tubing Increases System Performance

**Not Sure What To Order?  
We Can Help . . .**

**Call Our Customer Service  
Toll-free Number for Assistance.**

School, Shuttle, Transit

#### PART NO.

**10-9382**

#### SHIPPING NOTICE

Due to size and weight, this unit must be shipped by LTL Carrier.

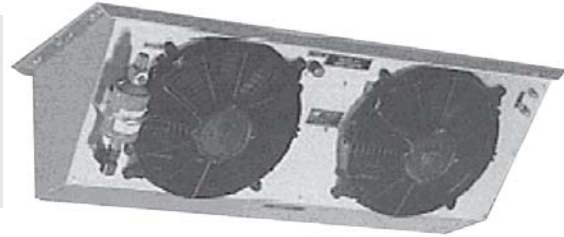

#### SPECIFICATIONS

Air Flow ..... 1850 CFM (3136 m3/hr)  
 Amperage Draw ..... 23 Amps @ 13.5 Volts  
 Cooling Capacity ..... 60,000 Btu/Hr (15,120 kcal)  
 Condenser Fans ..... 12" Diameter, Sealed Motor  
 Filter Drier/Sight Glass ..... 16 Cubic Inch  
 Mounting Slots ..... 7/16" x 3/4" Dia. (6 Places)  
 Voltage ..... 12v  
 Weight ..... 42 lbs.

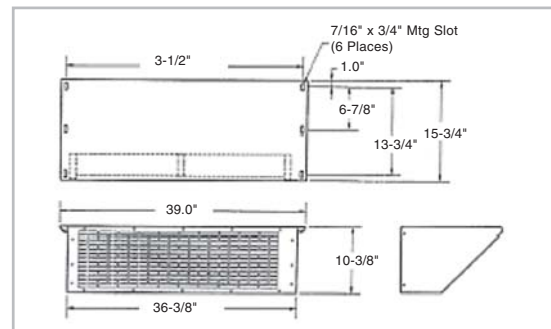

#### PART NO.

**10-9383**

#### SHIPPING NOTICE

Due to size and weight, this unit must be shipped by LTL Carrier.

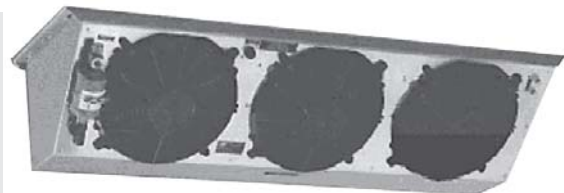

#### SPECIFICATIONS

Air Flow ..... 2775 CFM (4703 m3/hr)  
 Amperage Draw ..... 32 Amps @ 13.5 Volts  
 Cooling Capacity ..... 78,000 Btu/Hr (19,657 kcal)  
 Condenser Fans ..... 12" Diameter, Sealed Motor  
 Filter Drier/Sight Glass ..... 16 Cubic Inch  
 Mounting Slots ..... 7/16" x 3/4" Dia. (6 Places)  
 Voltage ..... 12v  
 Weight ..... 56 lbs.

