

**Basic Information**

Filter Driers (Receiver Driers), Accumulators and In-Line Filters are canisters used to filter debris and remove moisture to protect the a/c system. Various inlet and outlet fitting types and sizes are used. Many also have system protection devices, moisture indicators, charge ports, sightglass, fuse plugs, high pressure relieve valves, mounting brackets depending on the requirements from the original equipment manufacturer.

**Filter Driers (Receiver Driers)** are usually located on the high side of the a/c system before the expansion valve. The receiver drier “receives” liquid refrigerant from the condenser, stores it, filters out contaminants from the a/c system, and removes moisture. A/C systems using a receiver drier use an expansion valve to control the refrigerant flow.

**Accumulators** are similar to that of the receiver drier. It is usually mounted on the low side, at the outlet of the evaporator. The accumulator “accumulates” or stores excess refrigerant, filters and dries the refrigerant. Accumulators are used on CCOT (Cycling Clutch Orifice Tube) or FFOT (Ford Fixed Orifice Tube) systems. These systems use a orifice tube instead of an expansion valve to control the refrigerant flow.

**In-Line Filters** are designed to be used in the liquid line in a/c systems with the orifice tube located in the evaporator. Placing the in-line filter “up stream” of the orifice eliminates the need to flush most systems, because the impurities are trapped before they reach the orifice tube. These filters are designed to hold up to 90 grams of debris, without a substantial penalty to the system’s flow. The screens and filter pads inside the canister, catch particles and filters the refrigerant oil.



Filter Drier manufacturers have discontinued using moisture indicators. Truck Air will supply moisture indicators where applicable while supply lasts.

# FILTER DRIERS, ACCUMULATORS, & FILTERS (07- )

**SPECIFICATIONS .....370**

- Accumulators .....375**
- Block, Manifold, Pad or SlimLine Type.....370**
- Bus In-Line Driers .....395**
- Flare Type .....373**
- In-Line Filters .....374**
- O-Ring Type.....370**
- Quick Disconnect Type .....373**

**ILLUSTRATIONS.....377**

**DRIER MEASUREMENTS**

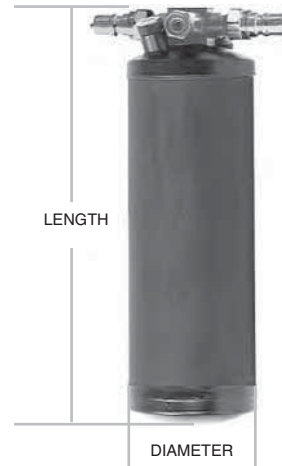

**RELATED ITEMS**

- Moisture Indicators.....377
- Mounting Bracket Kits .....377
- Quick Disconnect Fitting .....377

Moisture can be harmful to air conditioning systems components and to the a/c system's operation. For this reason, any time the a/c system is opened, the receiver drier / accumulator needs to be replaced. A good preventative maintenance practice is to replace the receiver drier or the accumulator and orifice tube at regular intervals or at least once per year. When replacing a compressor, the a/c compressor manufacturer's warranty will be void without proof of flushing the system, and also replacement of the receiver drier.

**Moisture Indicator** - (No longer supplied on newer driers.) A litmus paper device which turns colors to designate condition of the refrigerant. Blue - Normal, Pink - Moisture in system, White - Very Wet, Grayish - oil contamination.

**Pressure Relief Valve / Fuse Plug** - A protection device designed to open and "bleed off" excessive pressure that may occur. The Fuse Plug is a bi-metal device which will "melt down" to release excess pressure.

**Sightglass** - a "window" for observing the condition of the refrigerant.

**Schrader Valve** - a gauge or charge port which allows access to the system, for charging or checking the pressures.

**Switch Port - Low / High Pressure Switches** - a switch port allows for a male or female pressure switch to be added to the drier. If low charge is detected, the low pressure switch opens electronically and stops the compressor operation. Similarly, as pressure increases, the high pressure switch will dis-engage the clutch and re-engage when pressure normalizes.

**Typical Examples:** Moisture indicator is not required and may not be supplied on drier.

<p>Low / High Pressure Switch</p> <p>Sight Glass</p> <p>High Pressure Relief Valve</p>	<p>Quick Disconnect</p> <p>Charge/Gauge Port</p> <p>High Pressure Relief Valve</p> <p>Sight Glass</p> <p>Moisture Indicator (not required)</p> <p>Quick Disconnect</p>	<p>Sight Glass</p> <p>Moisture Indicator (not required)</p> <p>Charge/Gauge Port</p> <p>High Pressure Relief Valve (not on all models)</p> <p>Male O'Ring Type</p> <p>Female O'Ring Type</p> <p>Charge/Gauge Port</p>
<p>Slimline Manifold - Block Type</p>	<p>Male Flare Type (R12 only)</p> <p>Fuse Plug</p>	<p>Female Springlock Type</p> <p>Male Springlock Type</p>
<p>Pad Type</p> <p>Sight Glass (some models)</p> <p>Switch Port (some models)</p>	<p>Male O'Ring Type</p> <p>Female O'Ring Type</p> <p><b>TECH TIP</b> Metric Schrader Valve uses green o'ring seal.</p>	

Listed in ascending order by Diameter x Length by Fitting Type and Size.

**Block, Pad, Manifold, Slimline, or Springlock Style Fittings**

DIA.	LENGTH	TYPE	Inlet Size	Outlet Size	TRUCK AIR PART NO.	Sight Glass	Switch Port	Schrader Valve	Pressure Relief Valve	Note	Charge
1 5/8"	11-5/8"	Pad Type	o-ring 16-4206	o-ring 16-4206	07-0617A					Sprinter Van 680-013634AA	R134a
2 3/8"	7 1/2"	Pad Type	-	-	07-5072A					Volvo Exv EC Series, 14509377	R34a
2 3/8"	9"	Pad Type	-	-	07-5070A	Top	(2) Fem			JD Excavator, 4448179;4646799	R134a
2 .4"	10"	Pad Type	o-ring 0025	o-ring 16-4286	07-5057A					CAT 176-1902	
2 1/2"	7"	Pad Type	o-ring 16-4206	o-ring 16-4206	07-5055A					Caterpillar 113-3497	
2 1/2"	10"	PadType	o-ring 16-4206	o-ring 16-4206	07-5054A					CAT 176-1902; Komatsu 20Y-979-320	
2 3/4"	10"	Pad Type	-	-	07-5060A		(2)			Mitsubishi Fuso w/12.45mm ports (2)	
2.9"	9"	Pad Type	o-ring 16-4286	o-ring 16-4286	07-5058A		M10			3/8"-24 port; Linkbelt Exv YT54500003P1	
3"	10"	Slimline #6	seals 16-4263	seals 16-4263	07-0614A		(2) M10		Top	N83-319744	R134a
3"	10 1/4"	Slimline #6	seals 16-4263	seals 16-4263	07-0612A			(2) M10		N83-319534	R134a
3"	10 1/2"	Pad /Block	o-ring 16-4284	o-ring 16-4284	07-5053A			16mm		Volvo Off-Road 11104567	R134a
3"	11"	Manifold	o-ring 16-4206	o-ring 16-4206	07-1007A					Kenworth F37-6000	R134a
3"	11"	Pad Manifold	-	-	07-1008A					Peterbilt F37-6002	R134a
3"	11"	Pad Manifold	-	-	07-1009A					Peterbilt F37-6008	R134a
3"	11"	Pad Manifold	-	-	07-1010A					Peterbilt F37-6009	R134a
3"	14.35"	Springlock	SL 3/8" #6	SL 3/8" #6	07-5039A					Ford New Holland	R134a
4"	7"	Block Style	Stat Seal #8	Stat Seal #8	07-0619A					Frghtlnr A22-63992-000, -001	R134a
4"	7"	Block Style	Stat Seal #8	Stat Seal #8	07-0621A					Frghtlnr A22-63994-001	R134a
4"	7"	Pad Type	Stat Seal #8	Stat Seal #8	07-0620A					A22-63993-001, A22-65550-000	R134a
-	-	Pad Type	o-ring 16-4209	o-ring 16-4209	07-0615A					Sprinter Van 2.7L, 051-03570AA	R134a
-	-	-	Stat Seal 16-4267	Stat Seal 16-4267	07-0618A					Frghtlnr 22-66700-000	R134a
-	-	-	Stat Seal 16-4267	Stat Seal 16-4267	07-0622A					Frghtlnr 22-66600-000	R134a

**2 1/2" Diameter - 3/8" or M18 — Male O'Ring INLET w/VariouS Outlets**

DIA.	LENGTH	INLET	OUTLET	TRUCK AIR PART NO.	Sight Glass	Switch Port	Fuse Plug	Schrader Valve	Moisture Indicator	Pressure Relief Valve	Low Press. Switch	Note	Charge
2 1/2"	5.9"	3/8" #6	3/8" #6	07-3077A	Top	3/8"	Side					3/8 O'ring port; 085428-00	R12/R134a
2 1/2"	6 5/16"	3/8" #6	Course Thrd	07-3072A	Top	(1) M10						33-0038A	R12/R134a
2 1/2"	6 5/16"	M18	Fine Thread	07-3071A	Top	(1) M10						33-0382A	R12/R134a
2 1/2"	6 5/16"	M18	M18	07-3073A	Top	(1) M10						33-0383A	R12/R134a
2 1/2"	6 5/16"	M18	Fine Thread	07-3075A	Top	(1) M10						Motorhome 085686	R12/R134a
2 1/2"	6.32"	M18	M18	07-3076A	Top	(1) M10						RV218337, 085722	R134a
2 1/2"	6 3/4"	3/8" #6	MOR 1/2"#8	07-1804A								In-Line Design, GMC	R12/R134a
2 1/2"	6 3/4"	M18	MOR M20	07-1825A								In-Line Drier; 15982368	R12/R134a
2 1/2"	8"	3/8" #6	3/8" #6	07-0602A	Top	(2) Top						085268-03 (new style)	R12/R134a
2 1/2"	8"	3/8" #6	3/8" #6	07-3010A	Top	1/4" Male					Top	uses #11-3010 switch	R12/R134a
2 1/2"	8"	3/8" #6	MIO	07-3080A		3/8" Fem						085164	R134a
2 1/2"	8"	3/8" #6	MIO	07-3081A		1/4" Fem						16mm port; 085737	R134a
2 1/2"	8"	3/8" #6	FOR 3/8" #6	07-5600A	Top	(3)			Top			Univ. Allows Std or Metric Ftgs	R12/R134a
2 1/2"	8 1/4"	3/8" #6	3/8" #6	07-5019A	Top	Top						Bracket	R12/R134a
2 1/2"	10"	3/8" #6	3/8" #6	07-3054A								RD remote condenser	R12/R134a
-	-	3/8" #6	MIO	07-5069A								Volvo 20490945	R134a

## Section V: Specifications Chart

## Filter Driers, Accumulators & Filters

Listed in ascending order by Diameter x Length by Fitting Type and Size (continued).

### 2 3/4" Diameter — 3/8" Male O'Ring INLET x 3/8" Male O'Ring OUTLET

DIA. LENGTH INLET OUTLET				TRUCK AIR PART NO.	Sight Glass	Switch Port	Fuse Plug	Schrader Valve	Moisture Indicator	Pressure Relief Valve	Low Pressure Switch	Note	Charge
2 3/4"	10"	3/8" #6	3/8" #6	07-2603A	Top					Side	Side		R12/R134a
2 3/4"	10"	3/8" #6	3/8" #6	07-2618A	Top			1/4" Side		Side		Mack 221RD328	R12/R134a
2 3/4"	10"	3/8" #6	3/8" #6	07-1202A	Top	Side	Side					Mack 221RD327 w/Binary	R12/R134a
2 3/4"	10"	3/8" #6	3/8" #6	07-2604A	Top	Side				Side			R12/R134a
2 3/4"	10"	3/8" #6	3/8" #6	07-2610A	Top					Side		w/Trinary Sw - #11-2625	R12/R134a
2 3/4"	10"	3/8" #6	3/8" #6	07-0601A	Side	Top				Side		Kenworth K251-263	R12/R134a
2 3/4"	10"	3/8" #6	3/8" #6	07-2616A	Side			Top		Side		IHC1691600C92	R12/R134a
2 3/4"	10"	3/8" #6	3/8" #6	07-2611A	Side	Top				Side		w/ Trinary Switch - Top	R12/R134a
2 3/4"	10"	3/8" #6	3/8" #6	call	Top	Top	Top	1/4" Side		Side		Mack 221RD327, w/Binary	R12/R134a
2.6"	11 3/8"	3/8" MIO	3/8" MIO	07-5059A		(2) female						Hino Truck	R12/R134a
2.6"	11 3/8"	16-4286	16-4286	07-5059M		(2) female						Hino Truck, metric 7mm	R12/R134a

### 3" Diameter — 3/8" Male O'Ring INLET x 3/8" Male O'Ring OUTLET

DIA. LENGTH INLET OUTLET				TRUCK AIR PART NO.	Sight Glass	Switch Port	Fuse Plug	Schrader Valve	Moisture Indicator	Pressure Relief Valve	Low Pressure Switch	Note	Charge
3"	6"	3/8" #6	3/8" #6	07-0603A	Top	Side				Side			R12/R134a
3"	6"	3/8" #6	3/8" #6	07-2003A	Top		Side						R12/R134a
3"	6 1/4"	3/8" #6	3/8" #6	07-0400A	Side		Side						R12/R134a
3"	6 1/4"	3/8" #6	3/8" #6	07-5073A	Top	Female				Side		Terex Loader SKL863, SKL873	R134a
3"	6 1/2"	3/8" #6	3/8" #6	07-2621A	Top	Side			Top	Side		Red Dot RD5-7272-0	R12/R134a
3"	6 1/2"	3/8" #6	3/8" #6	07-2619A	Top			1/4" Side		Side		088423-00; 01	R12/R134a
3"	6 1/2"	3/8" #6	3/8" #6	07-2613A	Top		Side					Binary (Side)	R12/R134a
3"	6 1/2"	3/8" #6	3/8" #6	07-2614A	Top		Side					Trinary (Side)	R12/R134a
3"	6 1/2"	3/8" #6	3/8" #6	07-2620A	Top				Top	Side		N83-319634; RD5-9419-0	R12/R134a
3"	8"	3/8" #6	3/8" #6	07-1401A	Top		Side	(2) 1/4"					R12/R134a
3"	8 1/4"	3/8" #6	3/8" #6	07-0604A	Top	Top				Side			R12/R134a
3"	8 1/4"	3/8" #6	3/8" #6	07-0600A	Side	Top							R12/R134a
3"	8 1/4"	3/8" #6	3/8" #6	07-1605A	Top		Side	1/4" Side	Top				R12/R134a
3"	8 1/2"	3/8" #6	3/8" #6	07-2005A	Top	Female	Side	Side		Side	Side	Includes Low Press Switch	R12/R134a
3"	8"	3/8" #6	3/8" #6	07-1408A				Top (2)				(2) M10 x 1.25mm	R12/R134a
3"	9"	3/8" #6	3/8" #6	07-1603A	Top			1/4" Top	Top	Side			R12/R134a
3"	9"	3/8" #6	3/8" #6	07-1206A	Top	Side			Top	Side		1/8"-27NPT Port; 088254-01	R12/R134a
3"	9"	3/8" #6	3/8" #6	07-1606A					Top	Side			R12/R134a
3"	9"	3/8" #6	3/8" #6	07-1607A					Top	Top		Inlet - Right Angle	R12/R134a
3"	9 1/4"	3/8" MIO	3/8" MIO	07-1207A					Top			Mack 221RD44M	R134a
3"	9 3/4"	3/8" #6	3/8" #6	07-0426A	Top							w/side mounting bracket	R12/R134a
3"	10"	3/8" #6	3/8" #6	07-1609A	Top		Side	1/4" Side				Western Star	R12/R134a
3"	10"	3/8" #6	3/8" #6	07-1003A	Side			Top	Top	Side			R12/R134a
3"	10"	3/8" #6	3/8" #6	07-1004A	Top	Top			Top	Side			R12/R134a
3"	10"	3/8" #6	3/8" #6	07-1204A	Top			1/4" Top		Top			R12/R134a
3"	10"	3/8" #6	3/8" #6	07-1205A	Top			M10 Top	Top	Top		M10 x 1.25mm	R12/R134a
3"	10"	3/8" #6	3/8" #6	07-1001A	Side							088079-00; 176237; K251-459	R12/R134a
3"	10"	3/8" #6	3/8" #6	07-0427A	Top							w/side mounting bracket	R12/R134a
3"	10"	3/8" #6	3/8" #6	07-0440A	Top				Top			w/side mounting bracket	R12/R134a
3"	10"	3/8" #6	3/8" #6	07-1610A								Western Star 088586-00	R12/R134a

Listed in ascending order by Diameter x Length by Fitting Type and Size (continued).

**3" Diameter — 3/8" Male O'Ring INLET x 1/2" Male O'Ring OUTLET**

DIA. LENGTH INLET OUTLET				TRUCK AIR PART NO.	Sight Glass	Switch Port	Fuse Plug	Schrader Valve	Moisture Indicator	Pressure Relief Valve	Low Pressure Switch	Note	Charge
3"	6 1/2"	3/8" #6	1/2" #8	07-5074A		Male						CAT Exv., M318 / FNH EC270	R12/R134a

**4" Diameter — 3/8" Male O'Ring INLET x 3/8" Male O'Ring OUTLET**

DIA. LENGTH INLET OUTLET				TRUCK AIR PART NO.	Sight Glass	Switch Port	Fuse Plug	Schrader Valve	Moisture Indicator	Pressure Relief Valve	Low Pressure Switch	Note	Charge
4"	6 1/2"	3/8" #6	3/8" #6	07-5025A	Top		Side					w/mounting bracket	R12/R134a
4"	6 3/4"	3/8" #6	3/8" #6	07-5046A	Side							Volvo RD5-6075-0	R12/R134a
4"	7"	3/8" #6	3/8" #6	call	Top		Side					Ford Tractor E4NN-19825AA	R12/R134a
4"	7"	3/8" #6	3/8" #6	07-2007A	Top		Side					Opposite Side Inlet	R12/R134a
4"	7 3/4"	3/8" #6	3/8" #6	07-5021A	Top				Top	Side	Side		R134a
4"	8 1/2"	#6 MIO	#6 MIO	07-5026A	Top		Side		Top		Top	CAT 5V5698, 8P9991	R12/R134a

**3" - 4" Diameter — 3/8" Male O'Ring INLET x 3/8" Female O'Ring OUTLET**

DIA. LENGTH INLET OUTLET				TRUCK AIR PART NO.	Sight Glass	Switch Port	Fuse Plug	Schrader Valve	Moisture Indicator	Pressure Relief Valve	Low Pressure Switch	Note	Charge
3"	8"	3/8" #6	3/8" #6	07-0606A	Top			(2) 1/4"	Top	Side			R12/R134a
3"	8"	3/8" #6	3/8" #6	07-1400A	Top			(2) M10	Top	Side		(M10 x 1.25mm)	R12/R134a
3"	8 1/4"	3/8" #6	3/8" #6	call	Top			(2) 1/4"	Top	Top		Peterbilt 18-03638	R12
3"	10"	3/8" #6	3/8" #6	07-0608A	Top			(2) 1/4"	Top	Side		similar to #7135	R12/R134a
3"	10"	3/8" #6	3/8" #6	07-0610A	Top			(2) M10	Top	Side			R12/R134a
4"	7 3/4"	3/8" #6	3/8" #6	07-5043A									R12/R134a

**3" - 4" Diameter — 3/8" Female O'Ring INLET x 3/8" Male O'Ring OUTLET**

DIA. LENGTH INLET OUTLET				TRUCK AIR PART NO.	Sight Glass	Switch Port	Fuse Plug	Schrader Valve	Moisture Indicator	Pressure Relief Valve	Low Pressure Switch	Note	Charge
3"	10"	3/8" #6	3/8" #6	07-1005A	Side				Top			K251-459,K251-571,K251-566	R12/R134a
3"	10"	-	-	07-5066A	Top							Ford New Holland, 82012480	R12/R134a
3"	11 1/2"	3/8" #6	#6 MIO	07-5062A								JDeere, RE214440	R12/R134a
3"	11 1/2"	3/8" #6	#6 MIO	07-5063A								JDeere, AL163559 w/bracket	R12/R134a
4"	7"	3/8" #6	#6 MIO	07-5064A								JDeere, AL162467 w/bracket	R12/R134a
4"	7"	3/8" #6	3/8" #6	07-0811A	Top		Side						R12/R134a
4"	7 1/2"	3/8" #6	3/8" #6	07-5002A	(2) Side								R12/R134a
4"	7 1/2"	3/8" #6	3/8"-18	07-5038A	(2) Side							JDeere RE49169	R12/R134a
4"	7 3/4"	3/8" #6	#6 MIO	07-5061A								CASE, 86984155	R12/R134a
4"	8 1/2"	3/8" #6	3/8" #6	07-5077A								JDeere w/oe# AZ45582	R12/R134a
4"	8 3/4"	3/8" #6	3/8" #6	07-5032A	Side/Top				Top			JDeere AT162848; AT151981	R12/R134a



Listed in ascending order by Diameter x Length by Fitting Type and Size (continued).

**3" - 4" Diameter — 3/8" Female O'Ring INLET x 3/8" Female O'Ring OUTLET**

DIA. LENGTH INLET OUTLET				TRUCK AIR PART NO.	Sight Glass	Switch Port	Fuse Plug	Schrader Valve	Moisture Indicator	Pressure Relief Valve	Low Pressure Switch	Note	Charge
3"	10"	7/16" #6	3/8" #6	07-0803A	Top			Top	Top	Side		3/16" Charge Port	R12/R134a
3"	10"	11/16" #6	3/8" #6	07-0801A	Top		Top			Top		alternate #07-0803	R12/R134a
3"	10"	11/16" #6	3/8" #6	07-0804A	Top			16mm		Top		ParkerType; IHC 1693117C1	R134a
4"	9"	3/8" #6	3/8" #6	07-5024								Ford Tractor E2NN-19825AA	R12



Filter Drier manufacturers have discontinued using moisture indicators. Truck Air will supply moisture indicators where applicable while supply lasts.

**Flare End Fittings — Male INLET and Male OUTLET**

DIA. LENGTH INLET OUTLET				TRUCK AIR PART NO.	Sight Glass	Switch Port	Fuse Plug	Schrader Valve	Moisture Indicator	Pressure Relief Valve	Low Pressure Switch	Note	Charge
2 1/2"	6 3/4"	#6 Flare	#6 Flare	07-3052A								In-Line; 16cu.in.; WAH163	R12/R134a
2 1/2"	7"	1/2" Flare	1/2" Flare	07-3057A								In-Line ; WLD164FO; 16cu.in.	R12/R134a
2 1/2"	8"	#6 Flare	#6 Flare	07-3006A	Top								R12/R134a
2 1/2"	8"	#6 Flare	#6 Flare	07-1600A	Top			Top			Top	w/Low Pressure Sw.	R12/R134a
3"	6 1/4"	#6 Flare	#6 Flare	07-0400A	Top		Side					w/Fuse Plug	R12/R134a
3"	10"	1/2" Flare	1/2" Flare	07-3061A								In-Line; 30cu.in.; EK304	R12/R134a
4"	7 3/4"	#6 Flare	#6 Flare	07-5014	Top		Side					w/Fuse Plug	R12
4"	7"	#6 Flare	#6 Flare	07-0813A	Side		Side					w/Fuse Plug	R12/R134a

**Quick Disconnect Type**

DIA. LENGTH INLET OUTLET				TRUCK AIR PART NO.	Sight Glass	Switch Port	Fuse Plug	Schrader Valve	Moisture Indicator	Pressure Relief Valve	Low Pressure Switch	Note	Charge
2 1/2"	6"	QD	QD	07-1402A								In-Line; Peterbilt 18-03841	R134a
2 1/2"	6"	QD	QD	07-1406A	Top			(1) M10				(1) M10 x 1.25mm - Top	R12/R134a
2 1/2"	6 5/16"	3/8" #6	Course Thrd	07-3072A	Top			(1) M10				(1) Top M10 Male	R12/R134a
2 1/2"	6 5/16"	M18	Fine Thread	07-3071A	Top			(1) M10				(1) M10; 33-0382A	R12/R134a
2 1/2"	6 5/16"	M18	M18	07-3073A	Top			(1) M10				(1) M10; 33-0383A	R12/R134a
2 1/2"	6 5/16"	M18	Fine Thread	07-3075A	Top			(1) M10				Motorhome 085686	R12/R134a
2 1/2"	7 3/4"	QD	QD	07-5041A					Side			Incl. orifice tube; CAT3E3535	R134a
3"	9 5/8"	QD side	QD 60mm	07-0613A	Top			(2) M10				ABP N83 319524; 088470-01	R134a
3"	10"	QD	QD	07-0609A	Top			(2) 1/4"	Top			2 Schrader Vlvs (1/4" Top)	R134a
3"	10"	QD	QD	07-0611A	Top			(2) M10	Top			(2) M10 x 1.25mm (Top)	R134a
3"	10"	QD	QD	07-2009A	Top			16mm	Top	Side		R134a Service Port	R134a
3"	10"	QD	QD	07-1006A	Side				Top				R134a
4"	8 1/2"	QD	QD	07-5023A	Top				Top	Side	Side		R134a

Listed in ascending order by Diameter x Length by Fitting Type and Size (continued).

**In-Line Filters / Driers**

DIA.	LENGTH	INLET	OUTLET	TRUCK AIR PART NO.	Sight Glass	Pressure Relief Valve	Note	Charge
2 1/2"	6"	QD	QD	07-1402A			In-Line Drier; Peterbilt 18-03841	R134a
2 1/2"	6 3/4"	3/8" #6 Male O'Ring	1/2" #8 Male O'Ring	07-1804A			In-Line Design,GMC	R12/R134a
2 1/2"	6 3/4"	M18 Male O'Ring	M20 Male O'Ring	07-1825A			In-Line Drier; GMC 15982368	R12/R134a
2 1/2"	6 3/4"	3/8" #6 Male Flare	3/8" #6 Male Flare	07-3052A			In-Line Drier WAH 163; 16cu.in.	R12/R134a
2 1/2"	7"	1/2" Flare	1/2" Flare	07-3057A			In-Line Drier; WLD164FO; 16cu.in.	R12/R134a
2 1/2"	7"	1/2" Flare	1/2" Flare	07-3053A			In-Line Drier; WAH164; 16cu.in.	R12/R134a
2 1/2"	7 3/4"	QD	QD	07-5041A			Enclosed Orifice Tube; CAT3E3535	R134a
2 1/2"	7 3/4"	MIO Fitting	MIO Fitting	07-5056A			w/Orifice Tube, CAT# 257-3227	R134a
2 1/2"	10"	3/8" Male O'Ring	3/8" Male O'Ring	07-3054A			In-Line Drier, RD remote cond.	R12/R134a
2 1/2"	11"	1/2" SAE	1/2" SAE	07-3065A	Side		In-Line, Carrier WSG304; 30cu.in	R12/R134a
2 5/8"	7 1/2"	3/8" #6 Male	3/8" #6 Female	07-2011A		Side	16 cu.in. dessicant; Kysor 402618	R12/R134a
2 3/4"	8 1/2"	1/2" Flare	1/2" Flare	07-3064A	Side		In-Line Drier WSG164FO; 16cu.in	R12/R134a
2 3/4"	8 1/2"	1/2" #8 MIO	1/2" #8 MIO	07-3063A	Side		In-Line Retro; Carrier A/C; 16cu.in.	R12/R134a
3"	10"	1/2" Flare	1/2" Flare	07-3061A			In-LineTransAir #212-010; 30cu.in.	R12/R134a
3"	10 1/2"	5/8" SAE	5/8" SAE	07-3068A			In-Line, Carrier WAH305; 30cu.in.	R12/R134a
3"	10 1/2"	3/8" #6 Male	3/8" #6 Female	07-5076A	Side		FNH Backhoe 555E-685E; 85804063	R12/R134a
3"	11 1/2"	1/2" #8 MIO	1/2" #8 MIO	07-3066A	Side		In-Line, Carrier ADK304; 30cu.in.	R12/R134a
3 3/4"	10 3/4"	1/2" Flare	1/2" Flare	07-3055A			In-Line, TransAir AH414; 41cu.in.	R12/R134a
4"	7 1/2"	3/8" Female O'Ring	3/8"-18 Male O'Ring	07-5038A	(2) Side		In-Line Drier JDeere RE49169	R12/R134a

**Typical Drier System**

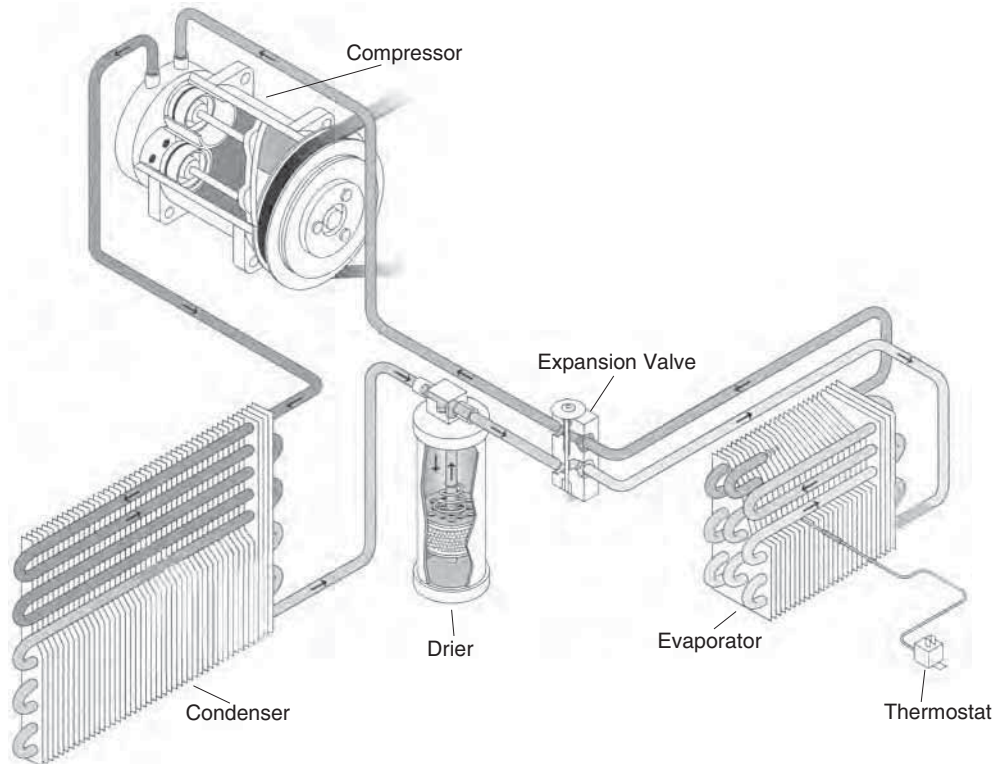

Listed in ascending order by Diameter x Length by Fitting Type and Size.

**Accumulators**

DIA.	Length	Inlet Type	Inlet Size	Outlet Type	Outlet Size	TRUCK AIR PART NO.	Note
2 7/16"	10"	Pad	16-4286	Pad	16-4286	07-5057A	CAT 176-1902
2 1/2"	7"	Pad	16-4206	Pad	16-4206	07-5055A	Caterpillar 113-3497
2 1/2"	10"	Pad	16-4206	Pad	16-4206	07-5054A	CAT 176-1902; Komatsu 20Y-979-320; Kubota
2 3/4"	10"	Pad	-	Pad	-	07-5060A	Mitsubishi Fuso w/12.45mm ports (2)
2 15/16"	9"	Pad	16-4286	Pad	16-4286	07-5058A	Linkbelt Exv YT54500003P1 (1) M10 port, (1) 3/8"-24 port
3"	8"	MIO	5/8" #10	MIO	3/4" #12	07-0444A	(2) 1/4" Ports, Ford F4TZ-19C836A, F6TZ-19C836AA
3 7/16"	9 1/2"	Pad	-	Pad	-	07-0815A	M12 Port; Navistar 3542577C2; BOA80-323-00-139
3 1/2"	8"	FOR	M27	MIO	M27	07-1834A	(1) M12 Port, GM 1132722, 2724924
3 1/2"	8"	FOR	3/4" #12	FOR	3/4" #12	07-0206A	Universal Type Accumulator; GM 12322992
3 1/2"	8"	Male Pad		Female Pad		07-1843A	(1) R143a Charge Port, (1) M12 Switch Port ; 1411812
3 1/2"	8 1/8"	MIO	5/8" #10	MIO	3/4" #12	07-0437 F, G	F6HZ-19C936A; 4C4H-19C808AA
3 1/2"	8 3/4"	Male SL	5/8" #10	Male SL	3/4" #12	07-0445A	(1) M10 Sw Port, (1) Chg Port 13mm; F4UZ-19C836A
3 1/2"	8 7/8"	Pad Type	#16-4277	-	-	07-0465A	Ford F250/350, 6C3Z-19C836A
3 1/2"	8 7/8"	Pad Type	#16-4277	FIOR	3/4" #12	07-0457A	F81Z-19C 836AA
3 1/2"	9"	FIOR	1/2" #8	FIOR	3/4" #12	07-0452A	Ford F9UZ-19C1836AB; F65Z-19C836AA
3 1/2"	9"	FOR	3/4" #12	MIO	3/4" #12	07-1808A	(2) 1/4" Ports, 2724802; 3090492
3 1/2"	9"	FOR	3/4" #12	MOR	3/4" #12	07-1820A	(2) 1/4" Ports, 1131394, 2724260
3 1/2"	9"	FOR	3/4" #12	MIO	3/4" #12	07-1816A	(2) 1/4" Ports; 1131506, 3059317, 27248336
3 1/2"	9"	FOR	3/4" #12	MOR	3/4" #12	07-1807A	(2) Serv Ports; 1131404, 2724266, 2724199, 2724804
3 1/2"	9"	FOR	3/4" #12	MIO	3/4" #12	07-1811A	(2) 1/4" Ports; GM 1131475, 2724877, 3057034, 3058262
3 1/2"	9"	FOR	M27	MIO	M27	07-1824A	w/M12 Port, 13mm R134a Port; 2724885, 2724665
3 1/2"	8"	FOR	3/4" #12	MOR	3/4" #12	07-1822A	(1) 1/4" Ports,w/R134a Port, R12 Port; 1131843; 2724689
3 1/2"	9"	FOR	M27	MOR	M27	07-1831A	(1) M12 Port, GM 2724817
3 1/2"	9"	FOR	M27	MOR	M27	07-1830A	(1) M12 Port (1) M13 Port, GM 2724902
3 1/2"	9"	FOR	M27	MOR	M27	07-1829A	(1) M12 Port (1) M13 Port, GM 2724847
3 1/2"	9"	FOR	3/4" #12	MIO	3/4" #12	07-1814A	w/M12 Port 1 3/4" below Fittings, GM 2724475
3 1/2"	9"	FOR	M27	MIO	M27	07-1833A	w/M12 Port 1 3/4" below Fittings, GM 2724899
3 1/2"	9"	FOR	M27	MIO	M27	07-1832A	(1) M12 Port (1) M13 Port, GM 2724886
3 1/2"	9"	Pad Type	Pad	MIO	M27	07-1837A	(1) M12 Port (1) M13 Port, GM 15005371
3 1/2"	9"	Male SL	3/4" #12	Female SL	#10 & #12	07-0448A	(2) 1/4" Ports, E69Z-19C836B
3 1/2"	10"	MIO	5/8" #10	MIO	3/4" #12	07-0430A	(2) 1/4" Ports, Ford E3TZ-19C836B, E7TZ-19C836A
3 1/2"	9"	Male SL	3/4" #12	Female SL	3/4" #12	07-0449A	(1) M12 Port (1) M13 Port, Ford E49Z-19C836C
3 1/2"	9 1/8"	FOR	1 1/16"	FOR	1 1/16"	07-1405A	Peterbilt 18-03837
3 1/2"	9 1/8"	FOR	1 1/16"	FOR	1 1/16"	07-5047A	Caterpillar 1018789 (steel)
3 1/2"	9 1/8"	Pad Type	-	-	Pad Type	07-1409A	Peterbilt 18-04171; 700075
3 1/2"	9 3/4"	FOR	#12 (1/16"-16)	FOR	#12 (1/16"-16)	07-5075A	CAT 186-6189
3 1/2"	9 13/16"	FOR	1 1/16"	FOR	1 1/16"	07-5052A	Caterpillar 089320-00, 197-6218
3 1/2"	10"	Female SL	3/8" #6	Female SL	5/8" #10	07-0436A	Two (2) Schrader Valves Top/Side
3 1/2"	12.3"	MOR	7/8"	MOR	7/8"	07-0443A	M12 switch port, F4HZ-19C836A; 089248-00
3 1/2"	-	-	-	-	-	07-0454A	Ford F7UZ-19C836BB
3 1/2"	-	-	-	-	-	07-0455A	Ford E75Z-19C836AA
3 1/2"	-	-	-	-	-	07-0458A	Ford XL3Z-19C836BA
3 1/2"	-	Pad Type	#16-4277	-	-	07-0459A	Ford XL3Z-19C836AA
3 1/2"	-	-	-	-	-	07-0460A	Ford F75Z-19C836BA
3 1/2"	-	-	-	-	-	07-0461A	Ford E-Series, 2C2Z-19C836BA
3 1/2"	-	-	-	-	-	07-0464A	w/ diesel eng. Ford E-Series, 4C2Z-19C836AA
3 1/2"	-	Pad Type	#16-4277	Springlock	#12	07-0466A	08 Fordw 8C3Z-19C836C (switch #11-0414)
3 1/2"	-	-	-	-	-	07-0816A	08 Navistar Prostar 3666273-C1, 3670134-C1

(continued)





Listed in ascending order by Diameter x Length by Fitting Type and Size (continued).

**Accumulators (continued)**

DIA.	Length	Inlet Type	Inlet Size	Outlet Type	Outlet Size	TRUCK AIR PART NO.	Note
3 1/2"	-	-	-	-	-	07-0817A	Navistar Prostar 3670134-C1; P6546001
3 1/2"	-	-	-	-	-	07-1838A	Topkick/Kodiak 1132813 (#16-4273 Stat Seal)
3 1/2"	-	-	-	-	-	07-1839A	GMC 04-06 Silverado 1411646
3 1/2"	-	-	-	-	-	07-1840A	GMC 01-05 Silverado Avalanche 1411647
3 1/2"	-	-	-	-	-	07-5065A	J. Deere 670D Grader AT190809, 803-465
3 1/2"	-	Stat Seal	#12	Stat Seal	#12	07-1841A	GMC 01-05 Silverado Avalanche 1411648
4"	10 1/4"	Pad	-	FIOR	3/4" #12	07-0456A	F85Z-19C836AB
-	-	Pad	16-4206	Stat Seal	#12	07-1842A	GMC G Series 2003-08, 25760829
-	-	MIO	#6	MIO	#6	07-0467A	Ford E-Ser. 7C2Z-19C836B

FIOR = Female Insert O-Ring  
 FOR = Female O-Ring  
 MIO = Male Insert O-Ring  
 MOR = Male O-Ring  
 SL = Springlock

**Typical Accumulator System CCOT Clutch Cycling Orifice Tube**

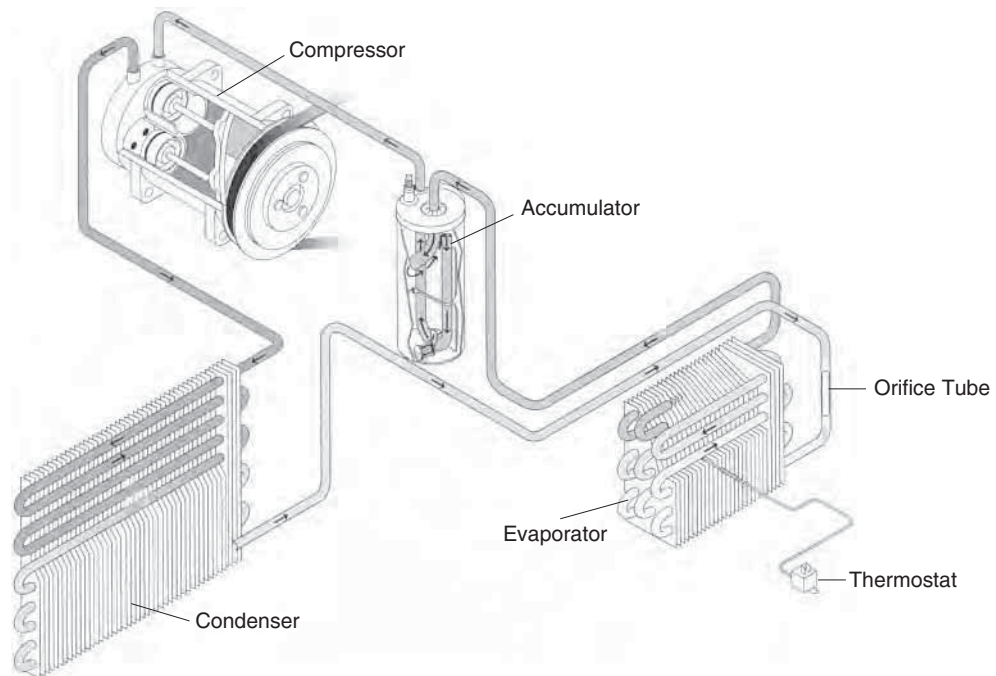



#6 = 3/8" #8 = 1/2" #10 = 5/8" #12 = 3/4"

**Moisture Indicators**

**NOTE:** Drier mfg's have discontinued using moisture indicators. Truck Air will supply moisture indicators where applicable while supply lasts.

 <p><b>07-3097</b> 3/8" Male Insert O-ring 3/8" Female O-ring Female Switch Port High Pressure Relief Valve w/switch use #07-3104</p>	 <p><b>07-3099</b> 3/8" Male Insert O-ring 3/8" Female O-ring High Pressure Relief Valve Male Schrader Port</p>	 <p><b>07-3101</b> 1/2" Male Flare 1/2" Female O-ring</p>	 <p><b>07-3103</b> 3/8" Male Insert O-ring 3/8" Female O-ring</p>
 <p><b>07-3104</b> 3/8" Male Insert O-ring 3/8" Female O-ring Low Pressure Switch High Pressure Relief Valve w/o switch use #07-3097</p>	 <p><b>07-3106</b> 3/8" Male Insert O-ring 3/8" Female O-ring Switch Port use #07-3093</p>		

**Quick Disconnect Fittings**

 <p><b>07-3028</b> QUICK DISCONNECT COUPLER 3/8" Male x Q.D. Length: 2-1/4" (1 per box)</p>	 <p><b>07-3031</b> Quick Disconnect COUPLER for IHC Applications 3/8" Female x Q.D. (1 per box)</p>
--	--

**Drier Brackets**

 <p><b>09-3312</b> Universal Drier Bracket For driers 2-1/4" to 3" in diameter</p>	 <p><b>09-3313</b> Heavy Duty Drier Bracket For driers 3" in diameter</p>	 <p><b>09-3316</b> Heavy Duty Compact Bracket For driers up to 4" in diameter</p>
---	--	---

# Filter Driers, Accumulators & Filters

# Section V: Illustrated

**NOTE:** Drier mfg's have discontinued using moisture indicators.  
Truck Air will supply moisture indicators where applicable while supply lasts.

#6 = 3/8" #8 = 1/2" #10 = 5/8" #12 = 3/4"

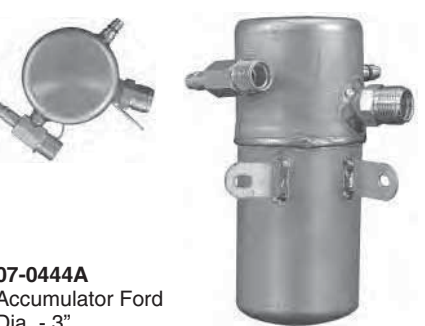



 <p><b>07-0206A</b> Universal Accumulator Dia. - 3-1/2" Lgth. - 8" In - 3/4" Female O'ring Out - 3/4" Female O'ring (2) R12 Ports</p> <p style="text-align: right;">GM 12322992</p>	 <p><b>07-0400A</b> Dia. - 3" Lgth. - 6-1/4" 3/8" x 3/8" Male Flare Top Sight Glass Fuse Plug</p>	 <p><b>07-0426A</b> Dia. - 3" Lgth. - 9-3/4" 3/8" x 3/8" Male O'ring Sight Glass</p>
 <p><b>07-0427A</b> Dia. - 3" Lgth. - 10" 3/8" x 3/8" Male O'ring Top Sight Glass</p>	 <p><b>07-0430A</b> Accumulator Ford Dia. - 3-1/2"; Lgth. - 10" In - 5/8" Male Insert O'ring Out - 3/4" Male Insert O'ring (2) 1/4" Ports</p> <p style="text-align: right;">E7TZ-19C836A</p>	 <p><b>07-0436A</b> Accumulator Dia. - 3-1/2" Lgth. - 10" In - 3/8" Female Springlock Out - 5/8" Female Springlock (2) Schrader Vlv (Top/Side)</p>
 <p><b>07-0437F</b> Accumulator Ford O.E. Style -Steel Dia. - 3-1/2" Lgth. - 8-1/8" In - 5/8" #10 MIO Out - 3/4" #12 MIO</p> <p style="text-align: right;">F6HZ-19C836A, F7HH-19E647AB, 4C4H-19C808AA</p>	 <p><b>07-0437G</b> Accumulator Ford Aftermarket Style Dia. - 3-1/2" Lgth. - 8-1/8" In - 5/8" #10 MIO Out - 3/4" #12 MIO</p> <p style="text-align: right;">F6HZ-19C836A</p>	 <p><b>07-0440A</b> Dia. - 3" Lgth. - 10" 3/8" x 3/8" Male O'ring Top Sight Glass Moisture Indicator</p>
 <p><b>07-0443A</b> Accumulator Dia. - 3-1/2" Lgth. - 12.3" 7/8" x 7/8" Male O'ring M12 Switch Port R134a Charge Port</p> <p style="text-align: right;">089248-00, F4HZ-19C836A</p>	 <p><b>07-0444A</b> Accumulator Ford Dia. - 3" Lgth. - 8" In - 5/8" Male Insert O'ring Out - 3/4" Male Insert O'ring (2) 1/4" Ports</p> <p style="text-align: right;">F4TZ-19C836A, F6TZ-19C836AA</p>	

# Section V: Illustrated

# Filter Driers, Accumulators & Filters

**NOTE:** Drier mfg's have discontinued using moisture indicators. Truck Air will supply moisture indicators where applicable while supply lasts.

#6 = 3/8" #8 = 1/2" #10 = 5/8" #12 = 3/4"

 <p><b>07-0445A</b> Accumulator Ford Dia. - 3-1/2" Lgth. - 8-3/4" In - 5/8" Male Springlock Out - 3/4" Male Springlock (1) Switchport M10, (1) Chg Port 13mm</p> <p>F4UZ-19C836A</p>	 <p><b>07-0448A</b> Accumulator Ford Dia. - 3-1/2" Lgth. - 9" In - 3/4" Male Springlock Out - 3/4" and 5/8" Female Springlock (2) 1/4" Ports</p> <p>E69Z-19C836B</p>	 <p><b>07-0449A</b> Accumulator Ford Dia. - 3-1/2" Lgth. - 9" In - 3/4" Male Springlock Out - 3/4" Female Springlock (1) M12 Port (1) M13 R134a Port</p> <p>E49Z-19C836C</p>
 <p><b>07-0452A</b> Accumulator Ford Dia. - 3 -1/2" Lgth. - 9" In - 1/2" #8 Female Insert O'ring Out - 3/4" #12 Female Insert O'ring F65Z-19C836AA</p>	 <p><b>07-0454A</b> Accumulator Ford F-Series F7UZ-19C836BB</p>	 <p><b>07-0455A</b> Accumulator Ford F75Z-19C836AA</p>
 <p><b>07-0456A</b> Accumulator Ford Dia. - 4" Lgth. - 10-1/4" In - PAD Out - 3/4" #12 Female Insert O'ring F85Z-19C836AB</p>	<p>Plastic housing not included. Must reuse old housing or use #07-0465A which includes the housing.</p> <p>16-4277 pad o-ring</p>  <p><b>07-0457A</b> Accumulator Ford Dia. - 3-1/2" Lgth. - 8-7/8" In - PAD Out - 3/4" #12 Female Insert O'ring F81Z-19C836AA</p>	 <p><b>07-0458A</b> Accumulator Ford XL3Z-19C836BA</p>
 <p>16-4277 pad o-ring</p> <p><b>07-0459A</b> Accumulator Ford XL3Z-19C836AA</p>	 <p><b>07-0460A</b> Accumulator Ford F75Z-19C836BA</p>	 <p><b>07-0461A</b> Accumulator Ford Truck E Series 2C2Z-19C836BA</p>



# Filter Driers, Accumulators & Filters

# Section V: Illustrated

**NOTE:** Drier mfg's have discontinued using moisture indicators.  
Truck Air will supply moisture indicators where applicable while supply lasts.

#6 = 3/8" #8 = 1/2" #10 = 5/8" #12 = 3/4"

 <p><b>07-0464A</b> Accumulator Ford E-Series w/diesel eng. 4C2Z-19C836AA</p>	 <p><b>07-0465A</b> Accumulator Dia. - 3-1/2" Lgth. - 8-7/8" Ford F250/350 6C3Z-19C836A (accumulator includes plastic housing)</p> <p>16-4277 pad o-ring</p>	 <p><b>07-0466A</b> Accumulator w/Hose Ford 2008-09 C3Z-19C836C</p> <p>11-0414 switch 16-4277 pad o-ring #12 o-rings Springlock</p>
 <p><b>07-0467A</b> Accumulator 3/8" x 3/8" Male Insert O'ring Ford E-Series 7C2Z-19C836B</p>	 <p><b>07-0469A</b> Accumulator (13-1/4"x7-1/2") Ford Transit-Connect O.E.# 9T1Z-19C836A; YF3625</p>	 <p><b>07-0600A</b> Dia. - 3" Lgth. - 8-1/4" 3/8" x 3/8" Male O'ring Side Sight Glass Top Switch Port PACCAR# 18-01800</p>
 <p><b>07-0601A</b> Dia. - 2-3/4" Lgth. - 10" 3/8" x 3/8" Male O'ring Side Sight Glass Top Switch Port Pressure Relief Valve Kenworth K251-263</p>	 <p><b>07-0602A</b> Dia. - 2-1/2" Lgth. - 8" 3/8" x 3/8" Male O'Ring Female Switch Port 1/4" Male Port Freightliner A22-14425-2; 085268-03</p>	 <p><b>07-0603A</b> Dia. - 3" Lgth. - 6" 3/8" x 3/8" Male O'ring Top Sight Glass Side Switch Port High Pressure Relief Valve</p>
 <p><b>07-0604A</b> Dia. - 3" Lgth. - 8 1/4" 3/8" x 3/8" Male O'ring Top Sight Glass Top Switch Port Pressure Relief Valve</p>	 <p><b>07-0606A</b> Dia. - 3" Lgth. - 8" In - 3/8" Male O'ring Out - 3/8" Female O'ring Top Sight Glass (2) Schrader Valves Moisture Indicator Pressure Relief Valve</p>	Empty cell



# Section V: Illustrated

# Filter Driers, Accumulators & Filters

**NOTE:** Drier mfg's have discontinued using moisture indicators.  
Truck Air will supply moisture indicators where applicable while supply lasts.

#6 = 3/8" #8 = 1/2" #10 = 5/8" #12 = 3/4"

 <p><b>07-0608A</b> Dia. - 3" Lgth. - 10" In - 3/8" Male O'ring Out - 3/8" Female O'ring Top Sight Glass (2) Schrader Valves Moisture Indicator Pressure Relief Valve ABPN83-319714</p>	 <p><b>07-0609A</b> Dia. - 3" Lgth. - 10" Quick Disconnect Top Sight Glass (2) 1/4" Schrader Valves Moist Indicator; R134a Only</p>	 <p><b>07-0610A</b> Dia. - 3" Lgth. - 10" In - 3/8" Male O'ring Out - 3/8" Female O'ring Top Sight Glass Pressure Relief Valve Moisture Indicator (2) Schrader Valves - M10</p>
 <p><b>07-0611A</b> Dia. - 3" Lgth. - 10" Quick Disconnect Top Sight Glass (2) Schrader Valves - M10 Moisture Indicator; R134a Only</p>	 <p><b>07-0612A</b> (Slimline Connection use #16-4263 Seal ) Dia. - 3" Lgth. - 10-1/4" 3/8" x 3/8" (2) M10 Switch Ports Moisture Ind; R134a Only ABPN83-319534</p>	 <p><b>07-0613A</b> Dia. - 3" Lgth. - 9-5/8" In - QD (side) Out - QD (top) Quick Discon. 60mm (2 3/8") (2) M10 Ports, Top Sight Glass ABPN83-319524; 088470-01</p>
 <p><b>07-0614A</b> Dia. - 3" Lgth. - 10" Slimline Connection (2) M10 Switch Ports Pressure Relief Plug ABPN83-319744</p>	 <p><b>07-0615A</b> Pad Style Drier 2003-06 Sprinter Van, 2.7TD 051-03570AA</p>	 <p><b>07-0617A</b> Dia. - 1-5/8" Lgth. - 11-5/8" Pad Style Drier 2007-08 Sprinter Van 680-013634AA</p>
 <p><b>07-0618A</b> Freightliner Cascadia A22-66700-000</p>	 <p><b>07-0619A</b> Dia. - 4" Lgth. - 7" Freightliner Columbia, M2 A22-63992-000, A22-63992-001</p>	 <p><b>07-0620A</b> Dia. - 4" Lgth. - 7" Freightliner A22-63993-001, A22-65550-000</p>

# Filter Driers, Accumulators & Filters

# Section V: Illustrated

**NOTE:** Drier mfg's have discontinued using moisture indicators.  
Truck Air will supply moisture indicators where applicable while supply lasts.

#6 = 3/8" #8 = 1/2" #10 = 5/8" #12 = 3/4"

<p>16-4267 #8 mini stat seal</p>  <p><b>07-0621A</b> Dia. - 4" Lgth. - 7" Freightliner Coronado A22-63994-001</p>	<p>16-4267 #8 mini stat seal</p>  <p><b>07-0622A</b> Freightliner M2 A22-66600-000</p>	 <p><b>07-0801A</b> Dia. - 3" Lgth. - 10" In - 11/16" Female O'ring Out - 3/8" Female O'ring Top Sight Glass Pressure Relief Valve</p>
 <p><b>07-0803A</b> Dia. - 3" Lgth. - 10" In - 7/16" Female O'ring Out - 3/8" Female O'ring Charge Port - 3/16" Moisture Indicator Pressure Relief Valve</p>	 <p><b>07-0804A</b> Dia. - 3" Lgth. - 10" In - 11/16" Female O'ring Out - 3/8" Female O'ring Top Sight Glass Pressure Relief Valve 16mm Service Port; R134a Only</p>	 <p><b>07-0811A</b> Dia. - 4" Lgth. - 7" In - 3/8" Female O'ring Out - 3/8" Male O'ring Top Sight Glass Side Fuse Plug</p>
 <p><b>07-0813A</b> Dia. - 4" Lgth. - 7" 3/8" x 3/8" Male Flare Sight Glass Side Fuse Plug</p>	 <p>16-4249 suction o-ring 16-4253 suction flange gasket M12</p> <p><b>07-0815A</b> Pad Mount Accumulator Dia. - 3-7/16" Lgth. - 9-1/2" Navistar 3542577C2; BOA80-323-00-139 uses 11-0834 sensor</p>	 <p>16-4248 discharge o-ring 16-4252 discharge flange gasket 16-4206 #6 o-ring</p> <p><b>07-0816A</b> Accumulator Assy. 2008 Navistar Prostar 3666273-C1</p>
 <p>16-4206 #6 o-ring 16-4248 discharge o-ring 16-4252 discharge flange gasket</p> <p><b>07-0817A</b> Accumulator Navistar Prostar 3670134-C1, P6546001</p>	 <p><b>07-1001A</b> Dia. - 3" Lgth. - 10" 3/8" x 3/8" Male O'ring Side Sight Glass Kenworth O.E. K251-459</p>	 <p><b>07-1003A</b> Dia. - 3" Lgth. - 10" 3/8" x 3/8" Male O'ring Side Sight Glass Top Schrader Valve Moisture Indicator Pressure Relief Valve</p>













# Section V: Illustrated

# Filter Driers, Accumulators & Filters

**NOTE:** Drier mfg's have discontinued using moisture indicators. Truck Air will supply moisture indicators where applicable while supply lasts.

#6 = 3/8" #8 = 1/2" #10 = 5/8" #12 = 3/4"











 <p><b>07-1004A</b> Dia. - 3" Lgth. - 10" 3/8" x 3/8" Male O'ring Top Sight Glass Top Switch Port Moisture Indicator Pressure Relief Valve</p>	 <p><b>07-1005A</b> Dia. - 3" Lgth. - 10" In - 3/8" Female O'ring Out - 3/8" Male O'ring Side Sight Glass Moisture Indicator Kenworth K251-566</p>	 <p><b>07-1006A</b> Dia. - 3" Lgth. - 10" Quick Disconnect Side Sight Glass Moisture Indicator; R134a Only</p>
 <p><b>07-1007A</b> Dia. - 3" Lgth. - 11" Pad Manifold Fittings R134a Only Kenworth T2000, F37-6000</p> <p>16-4206 o-rings</p>	 <p><b>07-1008A</b> Pad Manifold Fittings DayCab 330, 340, 387 Series PETERBILT F37-6002</p>	 <p><b>07-1009A</b> Dia. - 3" Lgth. - 11" Pad Manifold Fittings 365 thru 389 Series PETERBILT F37-6008</p>
 <p><b>07-1010A</b> Pad Manifold Fittings DayCab PETERBILT F37-6009</p>	 <p><b>07-1202A</b> Dia. - 2 3/4" Lgth. - 10" 3/8" x 3/8" Male O'Ring with Male Switch Port, Fuse Plug, &amp; Top Sight Glass, supplied w/ BinaryTM Switch</p> <p>Mack 221RD327</p>	 <p><b>07-1204A</b> Dia. - 3" Lgth. - 10" 3/8" x 3/8" Male O'ring Top Sight Glass Schrader Valve Pressure Relief Valve</p>
 <p><b>07-1205A</b> Dia. - 3" Lgth. - 10" 3/8" x 3/8" Male O'ring Top Sight Glass Pressure Relief Valve Moisture Indicator Metric Schrader Valve (M10)</p>	 <p><b>07-1206A</b> Dia. - 3" Lgth. - 9" 3/8" x 3/8" Male O'ring Top Sight Glass Pressure Relief Valve Side Sw Port (1/8"-27 NPT) Moisture Indicator</p> <p>088254-01</p>	 <p><b>07-1207A</b> Dia. - 3" Lgth. - 9 1/4" 3/8" x 3/8" MIO Moisture Indicator Mack 221RD44M</p>

# Filter Driers, Accumulators & Filters

# Section V: Illustrated

**NOTE:** Drier mfg's have discontinued using moisture indicators.  
Truck Air will supply moisture indicators where applicable while supply lasts.

#6 = 3/8" #8 = 1/2" #10 = 5/8" #12 = 3/4"

 <p><b>07-1400A</b> Dia. - 3" Lgth. - 8" In - 3/8" Male O'ring Out - 3/8" Female O'ring Top Sight Glass Pressure Relief Valve Moisture Indicator (2) Schrader Valves - M10</p>	 <p><b>07-1401A</b> Dia. - 3" Lgth. - 8" 3/8" x 3/8" Male O'ring (2) Schrader Valves</p>	 <p><b>07-1402A</b> In-Line Drier; R134a Only Dia. - 2-1/2" Lgth. - 6" (9.6" overall) In/Out Quick Disconnect Peterbilt 18-03841</p>
 <p><b>07-1405A</b> Accumulator Dia. - 3-1/2" Lgth. - 9-1/8" In - 1-1/16" Female O'ring Out - 1-1/16" Female O'ring Peterbilt 18-03837</p>	 <p><b>07-1406A</b> Dia. - 2-1/2" Lgth - 6" In/Out Quick Disconnect Top Sight Glass (1) Schrader Valve - M10</p>	 <p><b>07-1408A</b> Dia. - 3" Lgth. - 8" 3/8" x 3/8" Male O'ring (2) Schrader Valves - M10 PH088340-01</p>
 <p><b>07-1409A</b> Accumulator Dia. 3-1/2" Lgth. - 9-1/8" uses (2) #16-4212 o-rings and #08-1400SR fitting Peterbilt Pad, 18-04171</p>	 <p><b>07-1600A</b> Dia. - 2-1/2" Lgth. - 8" 3/8" x 3/8" Male Flare Top Sight Glass Top Schrader Valve Low Pressure Switch</p>	 <p><b>07-1603A</b> Dia. - 3" Lgth. - 9" 3/8" x 3/8" Male O'ring Top Sight Glass Top Schrader Valve Moisture Indicator Pressure Relief Valve</p>
 <p><b>07-1605A</b> Dia. - 3" Lgth. - 8-1/4" 3/8" x 3/8" Male O'ring Top Sight Glass Schrader Valve Moisture Indicator, Fuse Plug</p>	 <p><b>07-1606A</b> Dia. - 3" Lgth - 9" 3/8" x 3/8" Male O'ring Pressure Relief Valve Moisture Indicator</p>	 <p><b>07-1607A</b> Dia. - 3" Lgth. - 9" 3/8" x 3/8" Male O'ring Inlet - Right Angle Moisture Indicator Pressure Relief Valve</p>











# Section V: Illustrated

# Filter Driers, Accumulators & Filters

NOTE: Drier mfg's have discontinued using moisture indicators.  
Truck Air will supply moisture indicators where applicable while supply lasts.

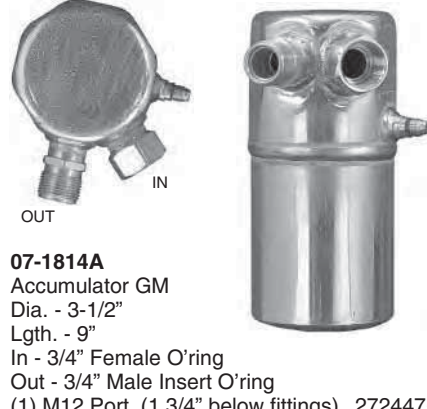
#6 = 3/8" #8 = 1/2" #10 = 5/8" #12 = 3/4"

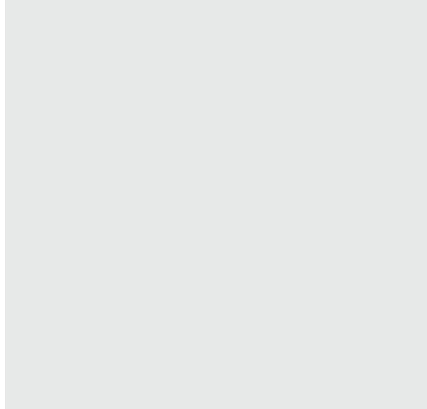
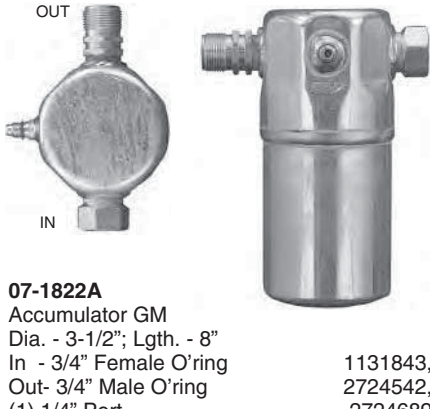
 <p><b>07-1609A</b> Dia. - 3" Lgth. - 10" In - 3/8" Male O'ring Out - 3/8" Male O'ring Top Sight Glass Fuse Plug, (1) 1/4" Port Western Star</p>	 <p><b>07-1610A</b> Dia. - 3" Lgth. - 10" In - 3/8" #6 Male O-ring Out - 3/8" #6 Male O-ring Western Star 088586-00</p>	 <p><b>07-1804A</b> Dia. - 2-1/2" Lgth. - 6-3/4" In - 3/8" Male O'ring Out - 1/2" Male O'ring In-Line Design, GMC</p>
 <p><b>07-1807A</b> Accumulator GM Dia. - 3-1/2"; Lgth. - 9" In - 3/4" Female O'ring Out - 3/4" Male O'ring (2) 1/4" Ports</p> <p>2724804</p>	 <p><b>07-1808A</b> Accumulator GM Dia. - 3-1/2" Lgth. - 9" In - 3/4" Female O'ring Out - 3/4" Male O'ring (2) 1/4" Ports</p> <p>2724802, 3090492</p>	 <p><b>07-1811A</b> Accumulator GM Dia. - 3-1/2"; Lgth. - 9" In - 3/4" Female O'ring Out - 3/4" Male Insert O'ring (2) 1/4" Ports</p> <p>2724877</p>
 <p><b>07-1814A</b> Accumulator GM Dia. - 3-1/2" Lgth. - 9" In - 3/4" Female O'ring Out - 3/4" Male Insert O'ring (1) M12 Port (1 3/4" below fittings)</p> <p>2724475</p>	 <p><b>07-1816A</b> Accumulator GM Dia. - 3-1/2"; Lgth. - 9" In - 3/4" Female O'ring Out - 3/4" Male Insert O'ring (2) 1/4" Ports</p> <p>1131506, 3059317</p>	 <p><b>07-1820A</b> Accumulator GM Dia. - 3-1/2"; Lgth. - 9" In - 3/4" Female O'ring Out - 3/4" Male O'ring (2) 1/4" Ports</p> <p>1131394, 2724260</p>
 <p><b>07-1822A</b> Accumulator GM Dia. - 3-1/2"; Lgth. - 8" In - 3/4" Female O'ring Out - 3/4" Male O'ring (1) 1/4" Port</p> <p>1131843, 2724542, 2724689</p>	 <p><b>07-1824A</b> Accumulator GM Dia. - 3-1/2"; Lgth. - 9" In - M27 x 2 5/8" Female O'ring Out - M27 x 2 5/8" MIO (1) M12 Port; (1) M13 R134a Port</p> <p>16-4260 o-rings</p> <p>2724665, 2724885</p>	









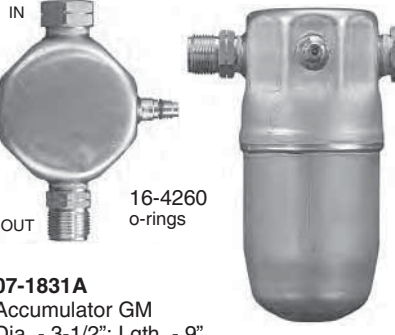
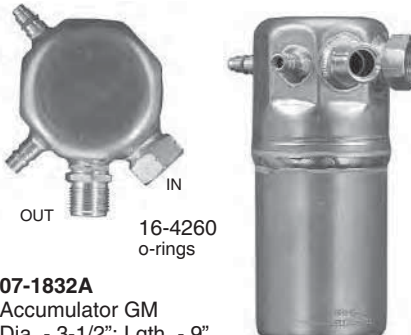

# Filter Driers, Accumulators & Filters

# Section V: Illustrated

**NOTE:** Drier mfg's have discontinued using moisture indicators.  
Truck Air will supply moisture indicators where applicable while supply lasts.

#6 = 3/8" #8 = 1/2" #10 = 5/8" #12 = 3/4"

 <p>16-4279 16-4280 o-rings</p> <p><b>07-1825A</b> Accumulator GM Dia. - 2-1/2"; Lgth. - 6-3/4" M18 Inlet x M20 Outlet Male O'ring In-Line Design, GMC 15982368</p>	 <p>IN OUT</p> <p>16-4260 o-rings</p> <p><b>07-1829A</b> Accumulator GM Dia. - 3-1/2"; Lgth. - 9" In -M27 Female O'ring Out -M27 Male O'ring (1) M12 Port; (1) M13 R134a Port</p> <p>2724847</p>	 <p>IN OUT</p> <p>16-4260 o-rings</p> <p><b>07-1830A</b> Accumulator GM Dia. - 3-1/2"; Lgth. - 9" In -M27 Female O'ring Out -M27 Male O'ring (1) M12 Port; (1) M13 R134a Port</p> <p>2724902</p>
 <p>IN OUT</p> <p>16-4260 o-rings</p> <p><b>07-1831A</b> Accumulator GM Dia. - 3-1/2"; Lgth. - 9" In -M27 Female O'ring Out -M27 Male O'ring (1) M12 Port</p> <p>2724817</p>	 <p>OUT IN</p> <p>16-4260 o-rings</p> <p><b>07-1832A</b> Accumulator GM Dia. - 3-1/2"; Lgth. - 9" In - M27 Female O'ring Out - M27 Male Insert O'ring (1) M12 Port; (1) M13 R134a Port</p> <p>2724886</p>	 <p>16-4260 o-rings</p> <p><b>07-1833A</b> Accumulator GM Dia. - 3-1/2"; Lgth. - 9" In - M27 Female O'ring Out - M27 Male Insert O'ring (1) M12 Port (1 3/4" below fittings)</p> <p>2724899</p>
 <p>IN OUT</p> <p>16-4260 o-rings</p> <p><b>07-1834A</b> Accumulator GM Dia. - 3-1/2"; Lgth. - 8" In -M27 Female O'ring Out -M27 Male Insert O'ring (1) M12 Port</p>	 <p>16-4273 seals 16-4260 o-rings</p> <p><b>07-1837A</b> Accumulator GM Dia. - 3-1/2"; Lgth. - 9" In - Pad Type Out -M27 Male Insert O'ring (1) M12 Port (1) M13 R134a Port</p> <p>1132722, 2724924</p>	 <p>16-4273 seals</p> <p><b>07-1838A</b> 2010-2003 Topkick/Kodiak OE# 1132813</p>
 <p>16-4273 seals</p> <p><b>07-1839A</b> Accumulator GMC (2004-06) Silverado, 4.3L OE# 1411646</p>	 <p>16-4273 seals</p> <p><b>07-1840A</b> Accumulator GMC (2001-05) Silverado, Avalanche OE# 1411647</p>	

# Section V: Illustrated

# Filter Driers, Accumulators & Filters

**NOTE:** Drier mfg's have discontinued using moisture indicators.  
Truck Air will supply moisture indicators where applicable while supply lasts.

#6 = 3/8" #8 = 1/2" #10 = 5/8" #12 = 3/4"



16-4273  
#12 stat seal

16-4260  
o-rings  
16-4273  
#12 stat seal

**07-1841A**  
Accumulator (rear)  
GMC Silverado, Avalanche; Tahoe, Yukon  
O.E.# 1411648; 19130064



**07-1842A**  
Accumulator  
2003-2008 GMC G Series O.E.# 25760829



**07-1843A**  
GMC C/K 10-35 Series  
(2nd design)  
Dia. - 3 1/2"  
Lgth. - 8"  
(1) Male Pad  
(1) Female Pad  
R134a Charge Port  
M12 Switch Port  
O.E.# 15827280; 1411812



**07-2003A**  
Dia. - 3"  
Lgth. - 6"  
3/8" x 3/8" Male O'ring  
Top Sight Glass  
Fuse Plug



**07-2005A**  
Dia. - 3"  
Lgth. - 8-1/2"  
3/8" x 3/8" Male O'ring  
Top Sight Glass  
Male Schrader Port  
Female Switch Port  
Low Pressure Switch  
Pressure Relief Valve



**07-2007A**  
Dia. - 4"  
Lgth. - 7"  
3/8" x 3/8"  
Male O'rings  
(opposite side inlet)  
Top Sight Glass  
Side Fuse Plug



**07-2009A**  
Dia. - 3"  
Lgth. - 10"  
Quick Disconnect  
Top Sight Glass  
Pressure Relief Valve  
R134a Service Port 16mm



**07-2011A**  
In-Line Drier  
Dia. - 2-5/8"  
Lgth. - 7-1/2"  
No. 6 (3/8") Male & Female  
Pressure Relief Valve  
16 cu. in. dessicant

Kysor  
402618



**07-2603A**  
Dia. - 2-3/4"  
Lgth. - 10"  
3/8" x 3/8" Male O'ring  
Top Sight Glass  
Side Low Pressure Switch  
Pressure Relief Valve



**07-2604A**  
Dia. - 2-3/4"  
Lgth. - 10"  
3/8" x 3/8" Male O'ring  
Top Sight Glass  
Side Switch Port  
Pressure Relief Valve



**07-2610A**  
Dia. - 2-3/4"  
Lgth. - 10"  
3/8" x 3/8" Male O'ring  
Top Sight Glass  
Side Trinary Switch  
Pressure Relief Valve

11-2625



**07-2611A**  
Dia. - 2-3/4"  
Lgth. - 10"  
3/8" x 3/8" Male O'ring  
Side Sight Glass  
Top Trinary Switch  
Pressure Relief Valve



# Filter Driers, Accumulators & Filters

# Section V: Illustrated

**NOTE:** Drier mfg's have discontinued using moisture indicators.  
Truck Air will supply moisture indicators where applicable while supply lasts.

#6 = 3/8" #8 = 1/2" #10 = 5/8" #12 = 3/4"













 <p><b>07-2613A</b> Dia. - 3" Lgth. - 6-1/2" 3/8" x 3/8" Male O'ring Top Sight Glass Side Binary Switch Fuse Plug</p>	 <p><b>07-2614A</b> Dia. - 3" Lgth. - 6-1/2" 3/8" x 3/8" Male O'ring Top Sight Glass Side Trinary Switch Fuse Plug</p>	 <p><b>07-2616A</b> Dia. - 2-3/4" Lgth. - 10" 3/8" x 3/8" Male O'ring Side Sight Glass Top Schrader Valve Pressure Relief Valve IHC OE# 1691600C92</p>
 <p><b>07-2618A</b> Dia. - 2-3/4" Lgth. - 10" 3/8" x 3/8" Male O'ring Top Sight Glass Side 1/4" Schrader Valve Pressure Relief Valve MACK OE# 221RD328</p>	 <p><b>07-2619A</b> Dia. - 3" Lgth. - 6-1/2" 3/8" x 3/8" Male O'ring Top Sight Glass Side 1/4" Schrader Valve High Pressure Relief Valve</p>	 <p><b>07-2620A</b> Dia. - 3" Lgth. - 6-1/2" 3/8" x 3/8" Male O'Ring Top Sight Glass, P.R.V. &amp; Moisture Indicator RD5-9419-0</p>
 <p><b>07-2621A</b> Dia. - 3" Lgth. - 6-1/2" 3/8" x 3/8" Male O'Ring Top Sight Glass Side Switch Port P.R.V. &amp; Moisture Indicator</p>	 <p><b>07-3006A</b> Dia. - 2-1/2" Lgth. - 8" 3/8" x 3/8" Male Flare Top Sight Glass</p>	 <p><b>07-3010A</b> 11-1030 switch Dia. - 2-1/2" Lgth. - 8" 3/8" x 3/8" Male O'ring Top Sight Glass Low Pressure Switch 1/4" Male Switch Port</p>
 <p><b>07-3052A</b> Dia. - 2-1/2" Lgth. - 6-3/4" 3/8" x 3/8" Male Flare 16 cu.in. In-Line Filter Drier WAH163</p>	 <p><b>07-3053A</b> Dia. - 2-1/2" Lgth. - 7" 1/2" x 1/2" Male Flare 16 cu. in. In-Line Drier WAH 164</p>	

# Section V: Illustrated

# Filter Driers, Accumulators & Filters

**NOTE:** Drier mfg's have discontinued using moisture indicators. Truck Air will supply moisture indicators where applicable while supply lasts.

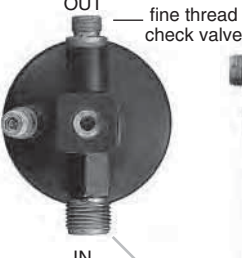
#6 = 3/8" #8 = 1/2" #10 = 5/8" #12 = 3/4"

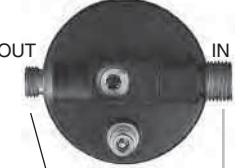
 <p><b>07-3054A</b> Dia. - 2-1/2" Lgth. - 10" 3/8" x 3/8" Male O'ring Red Dot remote condenser</p>	 <p><b>07-3055A</b> Dia. - 3-3/4" Lgth. - 10-3/4" 1/2" x 1/2" Male Flare 41 cu.in. dessicant TYPE AH414 In-LineDrier; TransAir A/C</p>	 <p>uses special o-rings #16-4130 (suplied)</p> <p><b>07-3057A</b> Dia. - 2-1/2" Lgth. - 7" 1/2" x 1/2" Male Flare 16 cu.in. In-Line Filter Drier WAH164FO</p>
 <p><b>07-3061A</b> Dia. - 3" Lgth. - 10" 1/2" x 1/2" Male Flare 30 cu.in. In-Line Filter Drier Transair #212-010; EK 304</p>	 <p>uses o-rings #16-4208</p> <p><b>07-3063A</b> Dia. - 2-3/4" Lgth. - 8-1/2" 16 cu.in. In-Line Filter Drier w/sight glass In/Out - 1/2" x 1/2" Male Insert O'ring CARRIER #14-00288-00; WSG 164 MIO</p>	 <p>uses special o-rings #16-4130 (suplied)</p>  <p><b>07-3064A</b> Dia. - 2-3/4" Lgth. - 8-1/2" 16 cu.in. In-Line Drier w/sight glass In/Out 1/2" Flare O'ring; WSG164 FO</p>
 <p><b>07-3065A</b> Dia. - 2-1/2" Lgth. - 11" 30 cu. in. In-Line Filter Drier w/sight glass In/Out 1/2" SAE; Carrier WSG304</p>	 <p>uses o-rings #16-4208</p> <p><b>07-3066A</b> Dia. - 3" Lgth. - 11-1/2" 30 cu. in. In-Line Filter Drier w/sight glass In/Out 1/2" Male Insert O'ring Carrier ADK304, WSG304MOI</p>	 <p><b>07-3068A</b> Dia. - 3" Lgth. - 10-1/2" 30 cu. in. In-Line Filter Drier In/Out 5/8" SAE Carrier WAH305</p>
 <p><b>07-3071A</b> Dia. - 2-1/2" Lgth. - 6-5/16" In - M18 Male O-ring Out - Fine Thread (1) M10 Port; Top Sight Glass 33-0382A</p>	 <p><b>07-3072A</b> Dia. - 2-1/2" Lgth. - 6-5/16" In - 3/8" Male O'ring Out - Course Thread (1) M10 Port; Top Sight Glass 33-0038A</p>	 <p>course thread check valve 16-4206 o-ring</p> <p><b>07-3072A</b> Dia. - 2-1/2" Lgth. - 6-5/16" In - 3/8" Male O'ring Out - Course Thread (1) M10 Port; Top Sight Glass 33-0038A</p>

# Filter Driers, Accumulators & Filters

# Section V: Illustrated

**NOTE:** Drier mfg's have discontinued using moisture indicators.  
Truck Air will supply moisture indicators where applicable while supply lasts.

#6 = 3/8" #8 = 1/2" #10 = 5/8" #12 = 3/4"

 <p><b>07-3073A</b> Dia. - 2-1/2" Lgth. - 6-5/16" In - M18 Male O-ring Out - M18 Male O-ring (1) M10 Port; Top Sight Glass</p>	 <p><b>07-3075A</b> Dia. - 2-1/2" Lgth. - 6-5/16" In - M18 Male O-ring Out - Fine Thread M10 Switch Port GM Chasis Motor Home</p>	 <p><b>07-3076A</b> Dia. - 2-1/2" Lgth. - 6.32" In - M18 Male O-ring Out - M18 Male O-ring Top Sight Glass M10 Switch Port</p>
 <p><b>07-3077A</b> Dia. - 2-1/2" Lgth. - 5.9" 3/8" x 3/8" Male O-ring Top Sight Glass Side Fuse Plug Port 3/8" O'ring</p>	 <p><b>07-3080A</b> Dia. - 2-1/2" Lgth. - 8" Male Insert O'rings Female 3/8"-24 Switch Port</p>	 <p><b>07-3081A</b> Dia. - 2-1/2" Lgth. - 8" 3/8" Male Insert O'rings 1/4" Female Switch Port 16mm Port OE# 085737</p>
 <p><b>07-5002A</b> Dia. - 4" Lgth. - 7-1/2" In - 3/8" Female O'ring Out - 3/8" Male O'ring (2) Side Sight Glass</p>	 <p><b>07-5014</b> Dia. - 4" Lgth. - 7-3/4" 3/8" x 3/8" Male Flare Top Sight Glass Fuse Plug, R12</p>	 <p><b>07-5019A</b> Dia. - 2-1/2" Lgth. - 8-1/4" 3/8" x 3/8" Male O'ring Top Sight Glass Switch Port</p>
 <p><b>07-5021A</b> Dia. - 4" Lgth. - 7-3/4" 3/8" x 3/8" Male O'ring Top Sight Glass Moisture Indicator Side Low Pressure Switch Pressure Relief Valve; R134a Only</p>	 <p><b>07-5023A</b> Dia. - 4" Lgth. - 8-1/2" Quick Disconnect Top Sight Glass Moisture Indicator Low Pressure Switch Pressure Relief Valve</p>	 <p><b>07-5024</b> Dia. - 4" Lgth. - 6" Horizontal Type In - 3/8" Female Piloted O'ring Fitting Out - 3/8" Female Piloted O'ring Fitting</p>













# Section V: Illustrated

# Filter Driers, Accumulators & Filters

**NOTE:** Drier mfg's have discontinued using moisture indicators. Truck Air will supply moisture indicators where applicable while supply lasts.

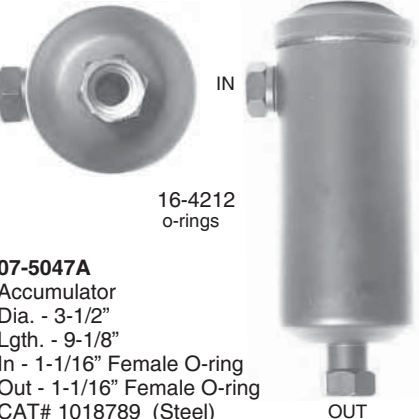
#6 = 3/8" #8 = 1/2" #10 = 5/8" #12 = 3/4"

















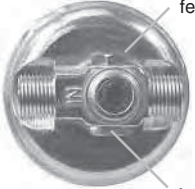

 <p><b>07-5025A</b> Dia. - 4" Lgth. - 6-1/2" 3/8" x 3/8" Male O'ring Top Sight Glass Side Fuse Plug</p>	 <p><b>07-5026A</b> Dia. - 4" Lgth. - 8-1/2" 3/8" x 3/8" MIO Combo: Sight Glass and Moisture Indicator Low Pressure Switch Port, CAT 5V5698, Sided Fuse Plug 8P9991</p>	 <p><b>07-5032A</b> Dia. - 4" Lgth. - 8-3/4" In - 3/8" Female O'ring Out - 3/8" Male O'ring Top Sight Glass Side Sight Glass Moisture Indicator John Deere AT125596, AT162848</p>
 <p><b>07-5038A</b> Dia. - 4 " Lgth. - 7-1/2" In - 3/8" Female O-ring Out - 3/8"-18 Male O-ring (2) Side Sight Glasses John Deere RE49169</p>	 <p><b>07-5039A</b> Dia. - 3" Lgth. - 14.35" #6 Spring Lock Connections Ford New Holland 89154-00</p>	 <p><b>07-5041A</b> Dia. - 2-1/2" Lgth. - 7-3/4" (13.88" OAL) Quick Disconnect Enclosed Orifice Tube Moisture Indicator; 134a Only CAT# 3E3535</p>
 <p><b>07-5043A</b> Dia. - 4" Lgth. - 7-3/4" In - 3/8" Male O-ring Out - 3/8" Female O-ring</p>	 <p><b>07-5046A</b> Dia. - 4" Lgth. - 6-3/4" 3/8" x 3/8" Male O'ring Side Sight Glass Volvo Off-Road VRE RD5-6075-0</p>	 <p><b>07-5047A</b> Accumulator Dia. - 3-1/2" Lgth. - 9-1/8" In - 1-1/16" Female O-ring Out - 1-1/16" Female O-ring CAT# 1018789 (Steel)</p> <p>16-4212 o-rings</p>
 <p><b>07-5052A</b> Accumulator Dia. - 3-1/2" Lgth. - 9-13/16" In - 1-1/16" Female O-ring Out - 1-1/16" Female O-ring CAT #089320-00; 197-6218</p> <p>16-4212 o-rings</p>	 <p><b>07-5053A</b> Pad Type Drier w/16mm port Dia. - 3" Lgth. - 10-1/2" VOLVO Off-Road O.E.# 11104567</p> <p>16-4284 o-ring</p>	

# Filter Driers, Accumulators & Filters

# Section V: Illustrated

**NOTE:** Drier mfg's have discontinued using moisture indicators.  
Truck Air will supply moisture indicators where applicable while supply lasts.

#6 = 3/8" #8 = 1/2" #10 = 5/8" #12 = 3/4"

 <p>16-4206 o-rings</p> <p><b>07-5054A</b> Pad Type Drier Dia. - 2-1/2" Lgth. - 10" Kubota 3F999-01740 Komatsu 20Y-979-320</p> 	 <p>16-4206 o-rings</p> <p><b>07-5055A</b> Pad Type Drier Dia. - 2-1/2" Lgth. - 7" CAT# 113-3497</p> 	 <p><b>07-5056A</b> Dia. - 2-1/2" Lgth. - 7-3/4" MIO fittings Enclosed Orifice Tube (13.88" OAL) CAT# 257-3227</p>
 <p>16-4286 o-rings</p> <p><b>07-5057A</b> Pad Type Drier Dia. - 2.4" Lgth. - 10" CAT# 176-1902</p> 	 <p>3/8-24 Port</p> <p>M10 Port</p> <p>16-4286 o-rings</p> <p><b>07-5058A</b> Pad Type Drier Dia. - 2.9" Lgth. - 9" Linkbelt Excavator OE# YT54500003P1</p> 	 <p><b>07-5059A</b> Dia. - 2.6" Lgth. - 11-3/8" 3/8" x 3/8" Male Insert O'ring HINO TRUCK</p> 
 <p>female port</p> <p>16-4286 o-rings</p> <p>female port</p> <p><b>07-5059M</b> Dia. - 2.6" Lgth. - 11-3/8" Metric Threads, Drier (2) Female Ports HINO TRUCK</p> 	 <p>12.45mm ports</p> <p><b>07-5060A</b> Dia. - 2-3/4" Lgth. - 10" Pad Type Drier (2) 12.45mm Ports MITSUBISHI FUSO</p> 	 <p><b>07-5061A</b> Dia. - 4" Lgth. - 7-3/4" In - #6 Female O'ring Out - #6 Male Insert O'ring CASE TRACTOR OE# 86984155</p>
 <p><b>07-5062A</b> Dia. - 3" Lgth. - 11-1/2" In - #6 Female O'ring Out - #6 Male Insert O'ring J. DEERE OE# RE214440, 088545-00</p>	 <p><b>07-5063A</b> Dia. - 3" Lgth. - 11-1/2" In - #6 Female O'ring Out - #6 Male Insert O'ring J. DEERE OE# AL163559, 088549-00</p>	 <p><b>07-5064A</b> Dia. - 4" Lgth. - 7" In - #6 Female O'ring Out - #6 Male Insert O'ring J. DEERE OE# AL162467</p>

# Section V: Illustrated

# Filter Driers, Accumulators & Filters

**NOTE:** Drier mfg's have discontinued using moisture indicators.  
Truck Air will supply moisture indicators where applicable while supply lasts.

#6 = 3/8" #8 = 1/2" #10 = 5/8" #12 = 3/4"

 <p><b>07-5065A</b> Accumulator Dia. - 3-1/2" J. DEERE, 670D Grader OE# 803-465, AT190809</p>	 <p><b>07-5066A</b> Dia. - 3" Lgth. - 10" Top Sight Glass FORD/NEW HOLLAND OE# 803-380, 82012480</p>	 <p><b>07-5067A</b> High Pressure Sw (bottom) Sight Glass (side) Moisture Indicator (top) CARRIER CM2 &amp; CM3 OE# 65-00193-00; 088599-01</p>
 <p><b>07-5068A</b> VOLVO Construction Equipment, A25B OE# 11005931</p>	 <p><b>07-5069A</b> 3/8" Male Insert O'ring VOLVO Loader OE# 20490945</p>	 <p><b>07-5070A</b> Pad Mount Drier Dia. - 2-3/8" Lgth. - 9" (2) 3/8" x 24 Female Sw Ports J. DEERE Excavators OE# 4448179; 464699</p>
 <p><b>07-5072A</b> Pad Mount Drier Dia. - 2-3/8" Lgth. - 7-1/2" VOLVO Excavators, EC Series OE# 14509377</p>	 <p><b>07-5073A</b> Dia. - 3" Lgth. - 6-1/4" In/Out - 3/8" x 3/8" Male O'ring Female Switch Port Pressure Relief Valve Top Sight Glass TEREX Wheel Loader SKL863, SKL873</p>	 <p><b>07-5074A</b> Dia. - 3" Lgth. - 6-1/2" In - #6 Male O'ring Out - #8 Male O'ring Male Switch Port CAT Exv., M318 / FNH Excavator EC270 OE# 73186213</p>
 <p><b>07-5075A</b> Accumulator w/o desiccant Dia. - 3-1/2" Lgth. - 9-3/4" In/Out - #12 Female O'ring (1/16" -16 thread) CAT Construction Equip. OE# 186-6189</p>	 <p><b>07-5076A</b> Dia. - 3" Lgth. - 10-1/2" In - #6 Male O'ring Out - #6 Female O'ring Switch Port, 7/16" Male Flare Side Sight Glass Top Mount Bracket FNH Backhole 555E-675E OE# 85804063</p>	



**NOTE:** Drier mfg's have discontinued using moisture indicators.  
Truck Air will supply moisture indicators where applicable while supply lasts.

#6 = 3/8" #8 = 1/2" #10 = 5/8" #12 = 3/4"

 <p><b>07-5077A</b> Dia. - 4" Lgth. - 8-1/2" In - 3/8" Female O'ring Out - 3/8" Male O'ring Combines, Forage Harvesters, Telehandlers OE# AZ45582</p>	  <p><b>07-5600A</b> UNIVERSIAL DRIER Dia. - 2-1/2" Lgth. - 8" In - 3/8" Male O-ring Out - 3/8" Female O-ring Top Sight Glass Moisture Indicator (3) 3/8"-24 Female Switch Ports</p>	
--	--	--

## Great for Service Trucks!

**07-5600A**  
UNIVERSIAL DRIER  
Allows the use of Standard or Metric Charge Port Fittings  
Dia. - 2-1/2"  
Lgth. - 8"  
In - 3/8" Male O'ring  
Out - 3/8" Female O'ring  
Top Sight Glass  
Moisture Indicator  
(3) 3/8" -24 Female Switch Ports



Has Multiple Charge Ports for use with Fitting Kit #16-4300.



**16-4300**  
UNIVERSIAL DRIER FITTING KIT  
Standand and Metric Charge Port Fittings  
Kit Contains:

P/N	Description
16-4206	..... 3/8" O-rings (10 ea.)
08-8060	..... 3/8" MOR to 3/8" MIO drier adapter (1 ea.)
08-8061	..... 11/16" MOR to 3/8" MIO drier adapter (1 ea.)
08-8058	..... 3/8"-24 male to M10 sw. port adapter (1 ea.)
08-8059	..... 3/8"-24 male to 12mm metric adapter (1 ea.)
08-8065	..... 3/8"-24 to 13mm charge port adapter (1 ea.)
08-8064	..... 3/8"-24 to 16mm charge port adapter (1 ea.)
08-8067	..... 7/16" FF to M10 Male sw. port adapter (1 ea.)
08-8069	..... M10 FF to 7/16" MF, R12 flare adapter (1 ea.)
08-3009	..... 3/8" MOR to Flare adapter (2 ea.)
08-8006	..... 3/8" MOR to 3/8" FF adapter (2 ea.)
08-8036A	..... 3/8" MOR, 3/8" FOR, R12 Inline Chg Ftg. (1 ea.)
03-8014	..... 3/8"-24, Pressure Relief Valve (1 ea.)
08-8057	..... 3/8"-24 male thrd. to 7/16" MF, R12 adpt. (2 ea.)
16-3143	..... Std. Valve Cores R12/R134a (5 ea.)



## BUS — IN-LINE DRIERS

DIA	LENGTH	FTG SIZE	FTG TYPE	CU.IN.	PART NO.
2.5"	6.75"	3/8" (#6)	Male Flare	16	<b>07-3052A</b>
2.5"	7"	1/2" (#8)	Male Flare	16	<b>07-3053A</b>
2.5"	7"	1/2" (#8)	Flare / O'ring	16	<b>07-3057A</b>
2.75"	8.5"	1/2" (#8)	Male Insert O'ring	16	<b>07-3063A</b>
2.75"	8.5"	1/2" (#8)	Flare / O'ring	16	<b>07-3064A</b>
3"	10"	1/2" (#8)	Male Flare	30	<b>07-3061A</b>
3"	10.5"	5/8" (#10)	Male Flare	30	<b>07-3068A</b>
3"	11.5"	1/2" (#8)	Male Insert O'ring	30	<b>07-3066A</b>
3.75"	10.75"	1/2" (#8)	Male Flare	41	<b>07-3055A</b>

Note: O'rings included on all Flare / O'ring style Driers



**07-3101**  
Moisture Indicator (FLARE)  
1/2" Male x 1/2" Female



**07-3052A**  
Dia. - 2-1/2"  
Lgth. - 6-3/4"  
16 cu.in. In-Line Filter Drier  
3/8" x 3/8" Male Flare; WAH163



**07-3053A**  
Dia. - 2-1/2"  
Lgth. - 7" 16 cu.in.  
16 cu. in. In-Line Drier  
1/2" Male Flare; WAH 164



**07-3055A**  
Dia. - 3-3/4"  
Lgth. - 10-3/4"  
41 cu.in. dessicant, 1/2" Flare  
TYPE AH414 In-Line Drier; TransAir A/C



uses special o-rings  
#16-4130 (supplied)

**07-3057A**  
Dia. - 2-1/2"  
Lgth. - 7"  
16 cu.in. In-Line Filter Drier  
1/2" Flare / O'ring; WAH164FO



**07-3061A**  
Dia. - 3"  
Lgth. - 10"  
30 cu.in. In-Line Filter Drier  
In/Out - 1/2" Male Flare; EK 304



uses o-rings #16-4208

**07-3063A**  
Dia. - 2-3/4"  
Lgth. - 8-1/2"  
16 cu.in. In-Line Filter Drier w/sight glass  
In - 1/2" Male Insert O'ring  
CARRIER # 14-00288-00; WSG164MIO



uses special o-rings  
#16-4130  
(supplied)

**07-3064A**  
Dia. - 2-3/4"  
Lgth. - 8-1/2"  
16 cu.in. In-Line Drier w/sight glass  
In/Out - 1/2" Flare / O'ring; WSG164 FO



uses o-rings  
#16-4208

**07-3066A**  
Dia. - 3"  
Lgth. - 11-1/2"  
30 cu.in. In-Line Filter Drier w/sight glass  
1/2" Male Insert O'ring  
Carrier ADK304, WSG304MOI



**07-3068A**  
Dia. - 3"  
Lgth. - 10-1/2"  
30 cu.in. In-Line Filter Drier  
5/8" SAE; Carrier WAH305